

# Keor HPE 200



TABLE OF CONTENTS	Page
1. Technical features .....	1
2. Block diagram.....	2
3. Options .....	2
4. Software enabled functions .....	2

## 1. TECHNICAL FEATURES

General Features	
Power (kVA)	200
UPS Topology	ON LINE - Double Conversion
Nominal apparent output power (kVA Cosφ 1.0)	200
Nominal active output power (kW Cosφ 1.0)	200
Efficiency (AC ÷ AC) (%)	
@25% load	up to 95
@50% load	up to 95,5
@75% load	up to 96
@100% load	up to 95,5
Efficiency (AC ÷ AC) (Eco Mode)	> 98
Heat dissipation at rated load, VFI voltage (kW)	9.4
UPS ambient temperature (°C)	0 ÷ 40
BATTERY ambient temperature (°C)	0 ÷ +25
UPS storage temperature (°C)	-10 ÷ +70
BATTERY storage temperature (°C)	-10 ÷ +60
Relative humidity % (non condensing)	< 95
Altitude m	< 1000 (Above Sea Level)
Power derating for altitude > 1000 m	According to "IEC62040-3", 0,5% every 100m
Ventilation	Forced
Requested cooling air volume (m³/h)	1800
Audible noise level (according to IEC EN 62040-3)	< 65
Number of cells for standard Lead acid battery	360 ÷ 372
Protection degree	IP20
Electromagnetic compatibility EMI	According to "IEC EN 62040-2" (CE marking)
Safety	IEC EN 62040-1
Test and performance	IEC EN 62040-3
Paint	RAL 9005
Accessibility	Front and side access
Installation	Against the wall
Dimensions (mm) (WxDxH)	850 x 953 x 1975
Weight kg (without battery)	720
Input/output cable connection	Cables input from bottom
Transport	Base provided for forklift handling
Storage and transport conditions	According to "IEC EN 62040-3"
Reference standards	EN 62040-1 - EN62040-2 - EN62040-3 ISO 9001:2008 - ISO 14001
Front panel	10" Touch-screen
Voltage-free contact interface	Optional for signalisations / alarms
Serial communication interface	Standard: RS232 - USB Optional: RS485 (Mod-Bus RTU protocol)
Parallel configuration (optional)	Up to 5+1 (redundant parallel) Up to 6 (power parallel)

Input: rectifier and battery charger	
Power (kVA)	200
Input	Three-phase
Nominal input voltage (Vac)	400
Input voltage range %	-20/+15
Input frequency (Hz)	50 – 60
Input frequency range	±10
Input power factor	> 0.99
Input current THD at nominal voltage and THDV <0,5% (%)	
@25% load	< 5
@50% load	< 4
@75% load	< 3
@100% load	< 3
DC output voltage accuracy (%)	±1
DC output voltage ripple (%)	1
Battery recharging characteristic	Intermittent charging with prevailing state of complete rest and control of the battery status IU (DIN 41773)
Maximum recharging current (A)	
- at nominal load	30
- with DCM function (max current)	100
AC-DC converter type	IGBT-based PFC
Input protection	Fuses
Nominal current absorbed from mains (at nominal load and battery charged) (A)	302
Maximum current absorbed from mains (at nom. load, nom. voltage and max. recharging current) (A)	338
Rectifier soft-start (walk-in) (sec)	Sectable from 5" to 30"
Rectifier sequential start-up (hold-off) (sec)	Sectable from 1" to 300"

Batteries	
Power (kVA)	200
Type (standard) other on request	Sealed lead acid (VRLA - maintenance free)
Number of Cells	360 – 372
Floating Voltage at 25°C	812 for 360 cells, 840 for 372 cells
Minimum Discharge Voltage Vdc	620 for 360 cells, 632 for 372 cells
Power drawn by the inverter (at rated load cosφ = 1)	204.3
Power drawn by the inverter (at rated load and minimum battery voltage)	330
Battery Protection	Fuses
Battery Test	Included as standard

# Keor HPE 200

## 1. TECHNICAL FEATURES *(continued)*

Output: Inverter	
Power (kVA)	200
Inverter Bridge	IGBT (High Frequency PWM)
Nominal apparent output power (kVA Cosφ 1.0)	200
Nominal active output power (kW Cosφ 1.0)	200
Efficiency (AC ÷ AC) (%)	
@25% load	97.2
@50% load	97.4
@75% load	98.0
@100% load	97.9
Output	Three-phase + Neutral
Nominal Output Voltage (selectable) (Vac)	380-400-415
Output Voltage Stability	
- Static (Balanced Load) (%)	± 1
- Static (Unbalanced Load) (%)	± 2
- Dynamic (Step Load 20%+ 100% ±20%) (%)	± 5
- Output Volt. Recovery Time(after step load) (ms)	< 20
- IEC EN 62040-3	VFI-SS-111
Phase Angle Accuracy	
- Balanced Load	± 1
- 100% Unbalanced Load	± 1
Output Frequency (selectable) (Hz)	50 - 60
Output Frequency Stability	
- Free Running Quartz Oscillator (Hz)	± 0,001
- Inverter Sync. with Mains (Hz)	± 2 (other on request)
- Slew rate (Hz/s)	< 1
Nominal Output Current (@ 400 Vac output) (A)	289
Overload Capability	
10 min	>100%...125%
30 s	>125%...150%
10 ms	>150%
Short Circuit Current (A)	720
Short Circuit Characteristic	Current limited with electronic protection Automatic stop after 5 seconds
Output Waveform	Sinusoidal
Output Harmonic Distortion (%)	
- Linear Load	< 1
- Non Linear Load	< 5
- IEC EN 62040-3	Fully compliant
Max Crest Factor without derating	3:1

Bypass	
Automatic static by-pass	Electronic Thyristor Switch
Protection	Fuses
Bypass	Three-phase + Neutral
Nominal input voltage (Vac)	380-400-415
Input voltage range (%)	±10
Input frequency (Hz)	50-60
Input frequency range (%)	±10
Transfer mode	Without break
Transfer inverter - automatic bypass	In case of: - Short-circuit - Battery discharged - Inverter test - Inverter failure
Retransfer automatic bypass - inverter	- Automatic - Block on bypass after 6 transfers within 2 minutes, reset by front panel
Overload Capability (%)	150 Continuously 1000 For 1 Cycle
Manual By-Pass	- Electronically controlled - No-break assisted re-start procedure
Back-feed protection	NC contact for the control of an external device

## 2. BLOCK DIAGRAM

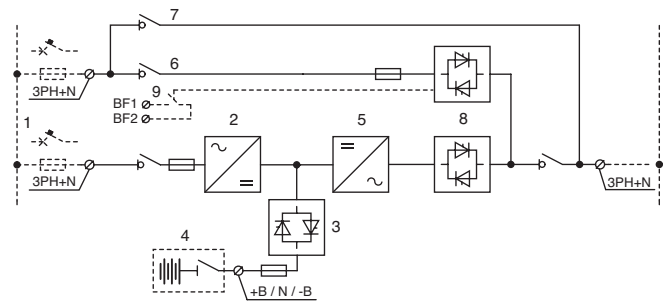

1. Separate mains input for rectifier and bypass
2. Rectifier battery-charger
3. Battery static switch
4. External battery
5. Inverter
6. Emergency line (bypass)
7. Maintenance bypass line
8. Inverter (SSI) and bypass(SSB) static switch
9. Optional contact for external back-feed protection

## 3. OPTIONS

1. BATTERY TEMPERATURE VOLTAGE COMPENSATION
2. SERIAL INTERFACE RS-485 (ModBus protocol RTU)
3. SNMP ADAPTER
4. PARALLEL CARD INTERFACE KIT
5. LOAD-SYNC CARD INTERFACE KIT
6. ISOLATION TRANSFORMER
7. WALL MOUNTED FUSED SWITCH BOX

## 4. SOFTWARE ENABLED FUNCTIONS

1. DIESEL MODE OPERATION
2. RECTIFIER WALK-IN TIME
3. RECTIFIER DELAY ON STARTUP (HOLD-OFF TIME)
4. DYNAMIC CHARGING MODE (DCM)
5. VFD (ECO) OPERATING MODE MANAGEMENT
6. UHE (ULTRA HIGH EFFICIENCY) OPERATING MODE MANAGEMENT
7. FREQUENCY CONVERTER