



TriMOD UPS

EN

ENGLISH

3



Contents

1	Introduction	6
1.1	General Remarks	6
1.2	Manufacturer's Liability and Guarantee	7
1.2.1	Guarantee terms	7
1.3	Copyright	7
2	Regulatory and Safety Requirements	8
2.1	Definitions of "Skilled Technician" and "Operator"	8
2.1.1	Skilled Technician	8
2.1.2	Operator	8
2.2	Personal Protective Equipment	9
2.3	Hazard Signs in the Workplace	9
2.4	Signs on the Equipment	9
2.5	Batteries	10
2.6	Installation and Maintenance	10
2.7	Cybersecurity	11
3	Equipment Check and Transportation	12
3.1	Visual check	12
3.2	Equipment Check	12
3.3	Unpacking	12
3.4	Transportation	14
3.5	Positioning Constraints	14
3.6	Fastening on the Floor	15
4	Installation	16
4.1	Electrical Connections	16
4.1.1	Wiring	18
4.1.2	Earthing	19
4.1.3	Protective Devices	19
4.1.4	Backfeed Protection	19
4.1.5	External Battery Cabinets Installation	24
4.1.5.1	Connection of One External Modular Battery Cabinet to the TriMOD 10-15-20-30TT/TM	25
4.1.5.2	Connection of One External Modular Battery Cabinet to the TriMOD 40TT/TM	26
4.1.5.3	Connection of Two External Modular Battery Cabinets (5KB) to the TriMOD 60	27
4.1.6	Mains Connection	28
4.1.7	Bypass Input Line Connection (if Separate)	28
4.1.8	Output Line Connection	28
4.2	Wiring Diagrams	29
4.2.1	Factory Configuration: 3-Phase Input – 3-Phase Output (with Common Bypass Input Line)	29
4.2.2	3-Phase Input – 3-Phase Output (with Separate Bypass Input Line)	31
4.2.3	3-Phase Input – 1-Phase Output (with Common Bypass Input Line)	32
4.2.4	3-Phase Input – 1-Phase Output (with Separate Bypass Input Line)	33
4.2.5	1-Phase Input – 1-Phase Output (with Common Bypass Input Line)	34
4.2.6	1-Phase Input – 1-Phase Output (with Separate Bypass Input Line)	34
4.2.7	1-Phase Input – 3-Phase Output 120°	36
4.2.8	Installation of the Connection Jumpers for TriMOD 10-15-20 kVA	37
4.2.9	Installation of the Connection Jumpers for TriMOD 30-40-60-80 kVA	38
4.2.10	Parallel System	40

Contents

4.3 Insertion of Power Modules and Battery Drawers	46
4.4 Communication Interfaces	47
4.4.1 Serial Communication Port	47
4.4.2 Emergency Power Off (EPO)	47
4.4.3 Input and Output Contacts	49
4.4.4 Network Card (SNMP) Slot	50
5 Configuration and Start-up	51
5.1 Pre-Start-Up Checks	51
5.2 Start-up Procedure	52
6 Maintenance	57
6.1 Preventive Maintenance	57
6.2 Periodical Checks	57
6.3 Extraordinary Maintenance	57
6.4 Maintenance procedure of the UPS in maintenance bypass mode	58
7 Warehousing	59
7.1 UPS	59
7.2 Batteries	59
8 Dismantling and Disposal	60
8.1 Battery Disposal	60
8.2 UPS Dismantling	60
8.3 Electronic Components Dismantling	60
9 Technical data	61
10 Tables	69
11 Dimensional Drawings	73
11.1 Cabinet with h = 1650 mm	73
11.2 Cabinet with h = 1370 mm	75
12 Battery Regulation	77

1. Introduction



Always verify the availability on UPservice of a complete and up-to-date revision of the manual.



1.1 General Remarks

This manual aims to provide skilled technicians with:

- Instructions for safely installing the UPS TriMOD, referred to as “equipment” throughout the manual.
- Information for performing ordinary maintenance procedures. Extraordinary maintenance operations are handled exclusively by LEGRAND’s Technical Support Service.

The manual references laws, directives, and standards that skilled technicians must be aware of and consult. It does not replace the expertise of technical personnel who must have received adequate preliminary training.

The intended use and configurations for the equipment, as shown in this manual, are the only ones allowed by LEGRAND (also referred to as “Manufacturer” throughout the manual). Any other use or configuration must be agreed upon in writing with the Manufacturer, and the written agreement will become part of the installation manual.

This manual is not a specification; therefore, LEGRAND reserves the right to make changes to data without prior notice. It complies with the directives and standards in force at the time of its release. The latest version of the manual is available at ups.legrand.com.

The original text of this publication, drafted in English, is the only reference for resolving disputes related to translations into other languages.

Some operations are indicated using graphic symbols to highlight danger or importance:



Indicates a high degree of risk that, if not avoided, will lead to death, serious injury, or considerable damage to the equipment, people, and surroundings.



Indicates a level of risk that, if not avoided, could lead to minor or moderate injury or material damage to the equipment, people, and surroundings.



Indicates important information that should be read carefully.

The manual must be kept in a safe, dry place and must always be available throughout its lifetime. It is recommended to make a copy and file it away. In case of damage that compromises its consultation, the skilled technician must obtain a new copy from the Manufacturer. When exchanging information with the Manufacturer or authorized assistance personnel, it is essential to refer to the equipment’s rating plate data and serial number.

1.2 Manufacturer's Liability and Guarantee

To ensure safety and proper operation, both the skilled technician and the operator must strictly follow the precautions outlined in the manual. They must:

- Always operate within the equipment's specified limits.
- Consistently perform careful maintenance through a skilled technician who adheres to all procedures in the installation and maintenance manual.

The Manufacturer disclaims all direct or indirect responsibility for:

- Assembly and cabling performed by personnel not qualified or authorized by LEGRAND, or not fully qualified according to national standards for working with electrical hazards.
- Assembly and cabling done without using the safety equipment and tools required by national safety standards.
- Failure to follow the installation, maintenance instructions, or use of the equipment in ways that differ from the user manual specifications.
- Use by personnel who have not read and fully understood the manual.
- Use that does not comply with the specific standards of the country where the equipment is installed.
- Unauthorized modifications to the equipment, software, or functioning logic.
- Repairs not authorized by the LEGRAND Technical Support Service.
- Damage caused intentionally, through negligence, by acts of God, natural phenomena, fire, or liquid infiltration.
- Damage caused by using batteries and protections not specified in the manuals.
- Damage caused by improper unloading and transportation after delivery.
- Accidents due to incorrect assembly of safety protections or failure to apply safety labels as specified in the installation manual.

When transferring the equipment to others, the manual must be handed over. Failure to do so will automatically nullify any rights of the buyer, including the guarantee terms where applicable. If the equipment is sold to another party in a country with a different language, the original owner is responsible for providing an accurate translation of the manuals in the language of the country where the equipment will be used.

1.2.1 Guarantee terms

The terms of the guarantee may vary depending on the country where the UPS is sold. Check the validity and duration with LEGRAND's local sales representative.

In case of a fault in the equipment, contact the LEGRAND Technical Support Service for instructions. Do not send anything back without LEGRAND's prior authorization.

The guarantee becomes void if the UPS has not been commissioned by a properly trained skilled technician (see paragraph 2.1.1).

If, during the guarantee period, the equipment does not meet the characteristics and performance specified in this manual, LEGRAND will, at its discretion, repair or replace the UPS and related parts. All repaired or replaced parts will remain LEGRAND's property.

LEGRAND is not responsible for costs such as:

- Loss of profits or earnings
- Loss of equipment, data, or software
- Claims by third parties
- Any damage to persons or property due to improper use, unauthorized technical alterations, or modifications
- Any damage to persons or property due to installations that do not fully comply with the standards regulating specific usage applications

The standard guarantee can be extended through a maintenance contract. After the guarantee period, LEGRAND offers technical assistance services, including maintenance agreements, 24/7 availability, and monitoring.

Please contact the LEGRAND Technical Support Service for further information.

1.3 Copyright

The information contained in this manual cannot be disclosed to any third party. Any partial or total duplication of the manual by photocopying or other systems, including electronic scanning, which is not authorized in writing by LEGRAND, violates copyright conditions and may lead to prosecution.

2. Regulatory and Safety Requirements



Before performing any operation on the equipment, read the entire manual carefully, especially this chapter. Keep this manual in a safe place and refer to it frequently during installation and maintenance by a skilled technician.



TriMOD 10 kVA is a category C2 UPS product. In a residential environment, this product may cause radio interference, in which case the user may be required to take additional measures. All the other TriMOD models are products for commercial and industrial application in the second environment - installation restrictions or additional measures may be needed to prevent disturbances.



The equipment is intended for the applications specified in this manual. It must not be used for purposes other than those for which it was designed or in ways different from those specified in this manual. All operations must be performed according to the criteria and sequence described in this manual.



Do not disable any safety, notification, or warning device, and do not ignore any alarm, warning message, or notice, whether they are generated automatically or represented by signs on the equipment.



In case of emergency, follow the regulations in force in the country where the equipment is installed.

2.1 Definitions of “Skilled Technician” and “Operator”

2.1.1 Skilled Technician

A “Skilled Technician” is the professional responsible for the installation, startup, and ordinary maintenance of the equipment. This term refers to individuals with specific technical qualifications who are knowledgeable about installing, assembling, repairing, commissioning, and safely using the equipment.

In addition to the general requirements for an operator, a Skilled Technician must be qualified according to the safety regulations in force in the country of installation, particularly regarding measures for working with hazardous voltage. They must also use the Personal Protective Equipment (PPE) required by the safety regulations in the country of installation for all activities specified in the installation and maintenance manual (see examples in paragraph 2.2).



The safety manager is responsible for protection and risk prevention within the company, as outlined in European directives 2007/30/EC and 89/391/EEC regarding workplace safety.

The safety manager must ensure that all personnel working on the equipment have received and understood the instructions included in the manuals, with particular emphasis on those contained in this chapter.

2.1.2 Operator

An “Operator” is the person assigned to the equipment for normal use. This term refers to individuals who know how to operate the equipment as described in the user manual and have the following qualifications:

- Technical education that enables them to operate according to safety standards related to electrical hazards.
- Training in the use of personal protective equipment and basic first aid.

When selecting an operator, the company safety manager must consider:

- The person’s work fitness according to current laws.
- Physical capability (no disabilities).
- Psychological stability (mental stability, sense of responsibility).
- Educational background, training, and experience.
- Knowledge of standards, regulations, and accident prevention measures.
- The safety manager should also provide thorough training to ensure the operator has a comprehensive understanding of the equipment and its components.

The operator must consult the manual at any time and follow the requirements to ensure maximum safety for themselves and others during all operating phases. Typical activities the operator is expected to perform include:

- Using the equipment in its normal functioning state and restoring its operation after shutdown.
- Taking necessary measures to maintain the UPS’s performance quality.
- Cleaning the equipment.
- Cooperating with personnel responsible for ordinary maintenance activities (skilled technicians).

2.2 Personal Protective Equipment



The UPS poses a significant risk of electric shocks and high short circuit currents. During installation, use, and maintenance operations, the equipment mentioned in this section must be used.



People responsible for operating this equipment or passing close to it must not wear garments with flowing sleeves, laces, belts, bracelets, or other metal items that might pose a danger.

The following list summarizes the minimum Personal Protective Equipment (PPE) that must always be worn. Additional requirements may be needed according to national safety standards:



Anti-accident and non-sparking shoes with rubber soles and reinforced toes



Protective gloves for handling operations



Insulated rubber gloves for connection operations and work under hazardous voltage



Protective garments for electrical work



Protective face and head shield



1000 V Insulated tools



The skilled technician must work on an electrically insulated carpet and must not wear any metal objects like watches, bracelets, etc.

2.3 Hazard Signs in the Workplace

The following signs must be displayed at all points of access to the room where the equipment is installed:



Electric current
Indicates electrical live parts.



Emergency procedures
Do not use water to extinguish fires; use extinguishers designed for electrical equipment fires.



No smoking
Indicates that smoking is not allowed.

2.4 Signs on the Equipment

Safety signs are displayed on the UPS to communicate warnings about potential dangers. Strictly comply with these instructions. Removing these signs or ignoring the warnings is prohibited.

Contact the Manufacturer if a sign deteriorates or becomes partially or fully illegible.



Potential risks can be drastically reduced by wearing the Personal Protective Equipment listed in this chapter. Always operate with due care around dangerous areas marked by the appropriate warning notices on the equipment.

2. Regulatory and Safety Requirements

2.5 Batteries



The UPS is powered by its own DC energy source (batteries). The output terminals may have a dangerous voltage even if the UPS is not connected to the AC power network. Disconnect all external battery cabinets before performing any installation or maintenance operation.



Batteries can present a risk of electrical shock and burns due to high short-circuit current. Failed batteries can reach temperatures that exceed safe touch thresholds. The following precautions should be observed when working on batteries:

- a) Remove watches, rings, or other metal objects.
- b) Use tools with insulated handles.
- c) Wear rubber gloves and boots.
- d) Do not lay tools or metal parts on top of batteries.
- e) Disconnect the charging source before connecting or disconnecting battery terminals.
- f) Determine if the battery is inadvertently grounded. If grounded, remove the source from the ground. Contact with any part of a grounded battery can result in electrical shock. The likelihood of shock can be reduced if grounds are removed during installation and maintenance (applicable to equipment and remote battery supplies not having a grounded supply circuit).
- g) Never leave live cable terminals without insulated protection.
- h) When replacing batteries, use the same type and number of batteries or battery packs. There is a risk of explosion if batteries are replaced with an incorrect type.

Do not dispose of batteries in a fire; they may explode.

Do not open or mutilate batteries. Released electrolyte is harmful to the skin and eyes and may be toxic. Batteries installed inside the cabinet must be disposed of correctly. Refer to local laws and relevant standards for disposal requirements.



The UPS must not be turned on if liquid is leaking from the batteries.



Do not open any battery breaker while the UPS is powering the loads in stored energy mode.

2.6 Installation and Maintenance



Any installation or maintenance operation must be performed only after the equipment has been disconnected from all power sources. Ensure there is no live voltage. Lock all remote switch disconnectors with an appropriate padlock to prevent them from being turned on.



The UPS must be installed with an earth connection to avoid high leakage currents. First, connect the earthing cable. During each installation and maintenance operation, check the continuity of the earthing system.





The UPS functions with TN-C, TN-S and TT systems. The output neutral status is the same as the input neutral status. When the output load requires a different neutral status, place a suitably scaled isolation transformer downstream of the UPS, which must be protected in compliance with current standards.

For electromedical applications requiring the medical IT system, an insulation board downstream of the UPS is necessary to ensure compliance with regulations for this type of application.

Due to the high leakage current to ground, TriMOD cannot be powered by an IT system. It can only be used in an IT system if the IT transformer is connected downstream of the UPS.

 To reduce the risk of fire or electric shock, the UPS must operate in closed, clean environments with controlled temperature and humidity. It must be kept away from flammable liquids and corrosive substances. The room temperature must not exceed +40°C (+104°F), and the relative humidity must be a maximum of 95% non-condensing.

 When replacing fuses, always use fuses of the same type.

 Do not run the equipment without fixed protections (e.g., panels) installed. If the equipment or any of its parts break, buckle, or malfunction, repair or replace them immediately.

 The equipment and workplace must be kept completely clean. Do not use oils or chemical products for cleaning, as they could scratch, corrode, or damage certain parts of the equipment. Upon completing installation or maintenance operations, before connecting the power supply, carefully check that no tools or materials have been left near the equipment. Depositing flammable materials near the equipment is forbidden.

 While maintenance operations are being carried out, "Maintenance work in progress" signs must be affixed in the department so they are easily visible from any access area.

 The skilled technician must not leave the key for opening the UPS door at the disposal of the operator.

2.7 Cybersecurity

 Physical security is essential to ensure the security of assets supplied by the UPS. The UPS must be installed in a restricted access area with access control and surveillance.

 Only limited authorized personnel should have access to the area where the UPS is installed.

 If the Legrand logo does not appear at startup, the device may be damaged or compromised, and it is necessary to contact the LEGRAND Technical Support Service.

 The UPS is designed to connect and share data via a network interface through the optional SNMP card, which should be connected to a secure network. It is the customer's sole responsibility to provide and continuously ensure a secure connection between the equipment and any network, and to establish and maintain appropriate measures to protect the UPS, the network, and the entire system against any kind of security breaches, unauthorized access, interference, intrusion, leakage, or theft of data.

 LEGRAND is not liable for damages or losses related to security breaches, unauthorized access, interference, intrusion, leakage, or theft of data. The customer is responsible for conducting periodic checks to ensure the system's functionality and that the security measures implemented have not been compromised.

3. Equipment Check and Transportation

3.1 Visual check

Upon delivery of the UPS, carefully inspect the packaging and the product for any damage that might have occurred during transport. Ensure there is no damage to the "Shock Watch" indicator on the outer label.

If there is possible or confirmed damage, immediately inform:

- The transporter and the shipping company
- LEGRAND Technical Support Service

Verify that the equipment matches the material listed in the delivery documentation. Follow the instructions in Chapter 8 for storing the UPS.



Mechanical damage to the electrical components constitutes a danger to people and property. In case of doubt regarding the non-integrity of the package or of the product contained therein, contact the Manufacturer before carrying out the installation and/or the start-up.

3.2 Equipment Check

The equipment and its supplied accessories must be in perfect condition. Check that:

- The shipping data (recipient's address, number of packages, order number, etc.) correspond to the delivery documentation.
- The technical rating plate data on the label applied to the UPS match the material purchased, as described in the delivery documentation.
- The documentation accompanying the equipment includes the installation manual.



If there are defects, missing items, or any discrepancies, immediately inform the LEGRAND Technical Support Service before commissioning the equipment.



When purchasing empty cabinets, power modules and battery drawers must be ordered separately.

3.3 Unpacking

To remove the packaging material, follow the graphic instructions on the outer box and the procedure outlined below:

1. Cut the plastic safety straps securing the packaging.

2. Open the top of the packaging and remove the accessory box.

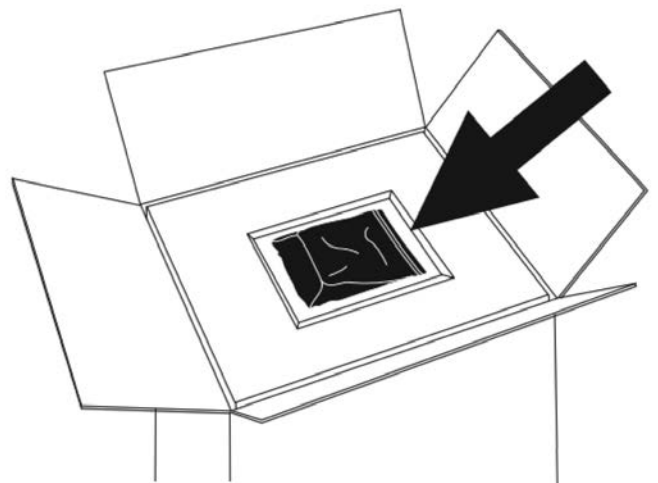
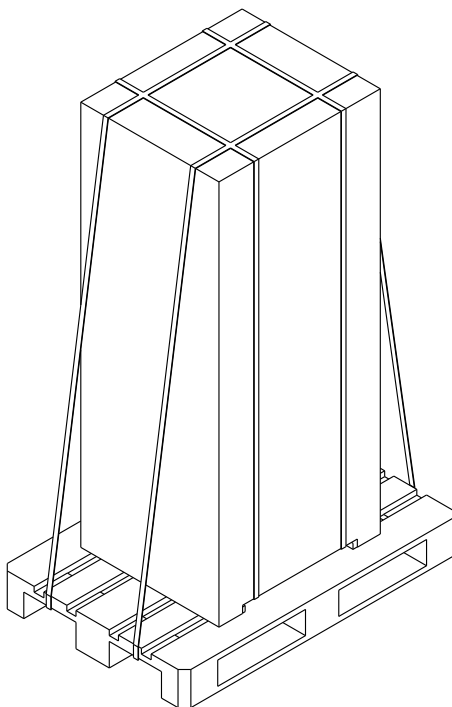

3. Lift off the outer carton to expose the UPS

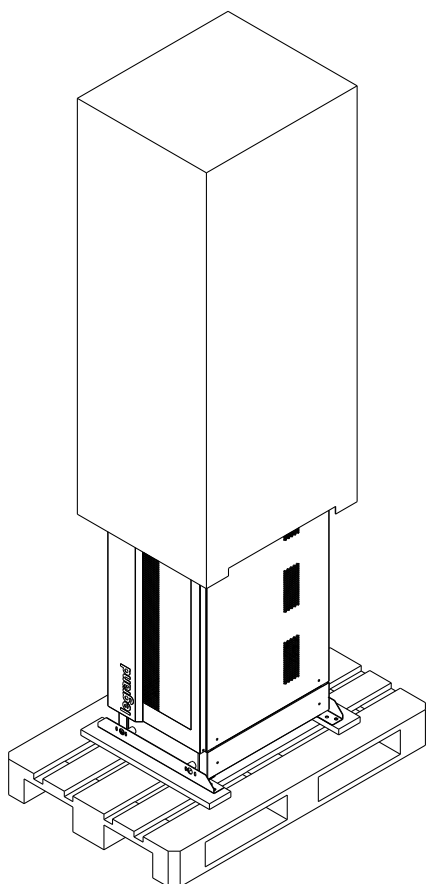

4. Remove the pallet

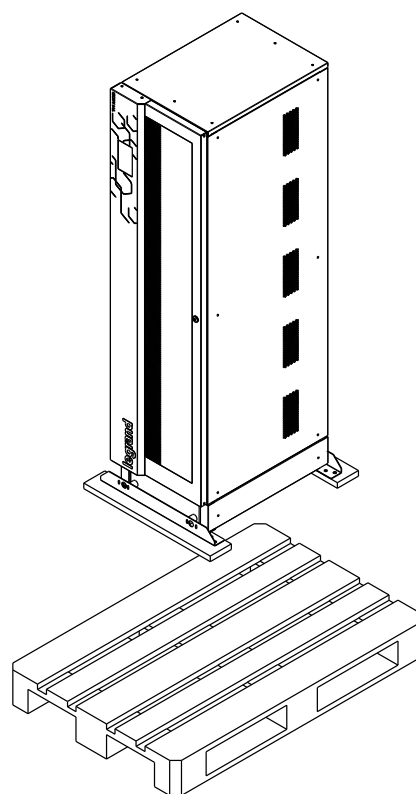

5. Remove the front and rear brackets from the UPS by unscrewing the retaining screws and keep them for the floor fastening (see par. 3.6)

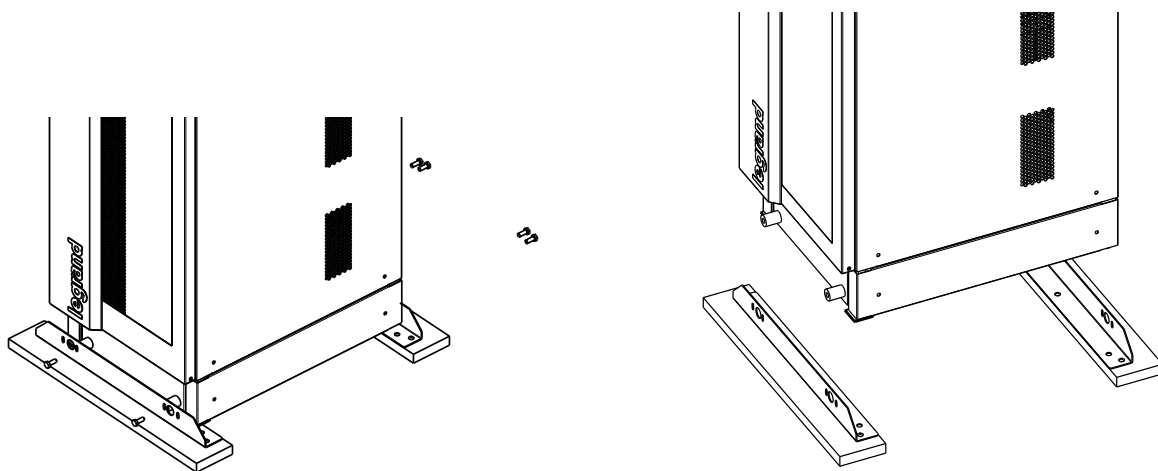

6. Inspect the UPS for any visible damage. If damage is found, notify the carrier and supplier immediately. Retain all packaging materials in case the unit needs to be returned or shipped again.

3. Equipment Check and Transportation

3.4 Transportation



Avoid turning over the UPS during transport. Cabinets must always be handled in an upright position. During loading and unloading, always follow the indications marked on the package. Avoid dangerous swings or falls. For lifting, use a forklift or pallet truck with adequate carrying capacity, placing the forks in the wooden base and ensuring they extend at least twenty centimeters beyond the other side.



Avoid bending or deforming the components and altering the insulation distances while transporting and handling the equipment.



Do not ship the equipment with any flammable, explosive, or corrosive items. Do not expose the package to rain or other adverse weather conditions.



Do not move the UPS after installation or after inserting power modules and any battery drawers.



The equipment must always be handled by trained and instructed personnel. Comply with the safety regulations in force in your country regarding the use of lifting equipment and accessories.

3.5 Positioning Constraints

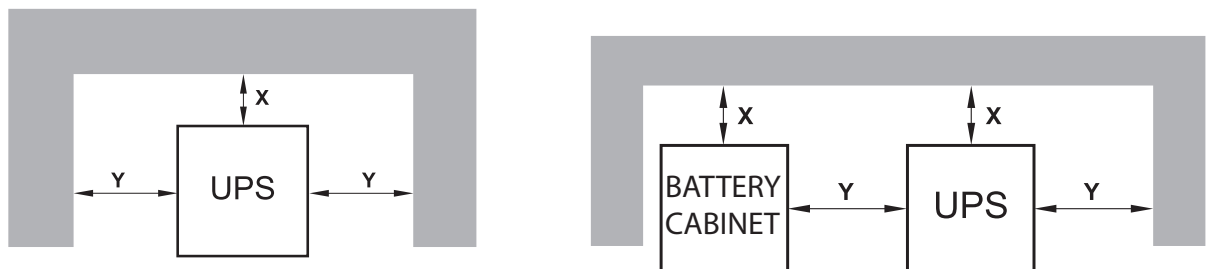

Minimum recommended distances
 $X=100\text{ mm} / Y=200\text{ mm}$

The UPS must be positioned according to the following conditions:

- Temperature and humidity must be within permitted limits.
- Fire regulations must be respected.
- Wiring must be simple.
- Front and rear accessibility must be available for assistance or periodic servicing.
- The cooling airflow must be guaranteed. Poor ventilation can reduce the service life of internal components and affect the life span of the UPS.
- The air conditioning system must be adequately scaled.
- Dust or corrosive/explosive gases must be absent.
- The premises must be free of vibration.
- Rear and side space must be sufficient to ensure adequate air circulation for cooling.
- The support surface must be scaled to the carrying capacity necessary to support the equipment.

3.6 Fastening on the Floor

The TriMOD UPS must be securely fastened to the floor to ensure proper stability.

During step 5 of the unpacking process (see par. 3.3), two brackets were removed from the front and rear of the UPS. To detach each bracket from the wooden base, remove the three screws securing it in place.

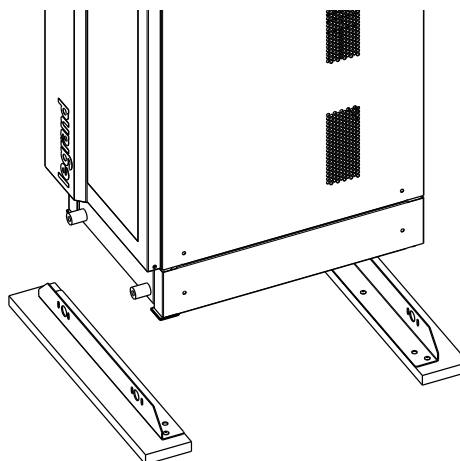

Reattach the brackets to the front and rear of the UPS by rotating them into position. Ensure the side with the three holes is oriented correctly to allow secure fastening of the cabinet to the floor.

Use the retaining screws removed during step 5 of the unpacking process to fix the brackets to the cabinet.



Use three suitable wall plugs and M6 screws appropriate for the type of floor where the UPS will be installed.

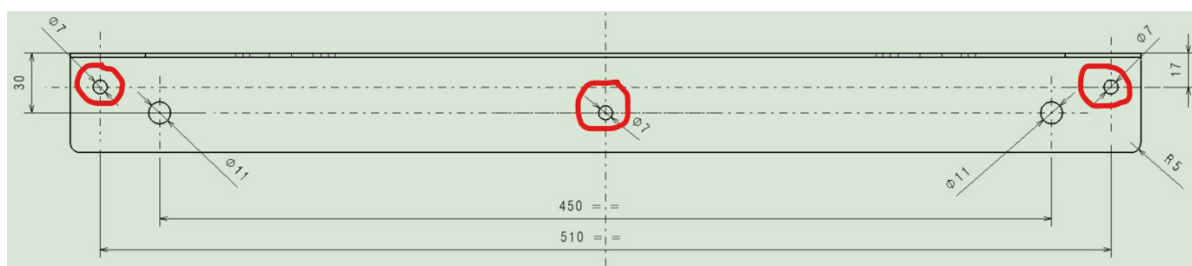

4. Installation



All UPS installation operations must be carried out exclusively by a skilled technician (paragraph 2.1.1).

4.1 Electrical Connections

The electrical connection of the UPS to the switchgear is a part of the installation process that is typically not performed by the UPS manufacturer. All electrical connections must comply with applicable local installation standards. After unpacking the UPS and positioning it in its final location, a qualified technician may proceed with the electrical connections.



Before performing any installation work, you must read and follow the safety instructions below:

1. High Leakage Current. It is essential to connect the earth (ground) before supplying power. The existing earthing system must have been implemented in compliance with IEC standards or applicable local regulations.
2. Fixed Installation Only. The UPS must be installed as a fixed unit, with a thermal-magnetic circuit breaker installed upstream. Connection to the mains via a standard plug is not permitted.
3. Backfeed Protection. An external circuit for protection against voltage backfeed must be installed, as shown in the diagrams in paragraph 4.1.4.
4. Accessible Disconnect Device. A switchgear or disconnect switch must be installed near the UPS and must be easily accessible.
5. Input Voltage and Frequency Check. Ensure that the mains input voltage and frequency match the values specified in the technical data on the UPS rating plate.
6. Upstream Protection Devices. The electrical system must be equipped with the required residual-current and thermal-magnetic protection devices upstream of the UPS input.
7. Warning Labels on Remote Disconnects. A warning label must be placed on all mains disconnect switches located away from the UPS area. This is to alert service personnel that the circuit is powered by a UPS. The label must display the following text (or an equivalent):

Before working on this circuit

- Isolate the Uninterruptible Power System (UPS)
- Then check for the presence of Hazardous Voltage between all terminals including the protective earth.



Risk of Voltage Backfeed



The selection of cable types and their cross-sections, based on rated current and installation conditions, must follow the applicable installation standards. This responsibility lies with the qualified technician. The connection cables must support a maximum operating temperature of at least 70°C.

The input current and output power of the UPS are specified in Chapter 9, while the battery current is listed in Table 4 of Chapter 10. Chapter 10 provides also detailed guidance on sizing cables, fuses, and selecting automatic and residual-current circuit breakers.

All electrical connection operations must be performed on the terminal strips located inside the UPS.

- For TriMOD 10, 15, 20, and 30 TT models:
Unscrew the distribution drawer locking screws and pull the drawer outward to access the distribution terminal strip.
- For TriMOD 30 TM, 40 TM, 40 TT, 60, and 80 models:
Remove both lower panels to access the distribution terminal strip.



The maximum tightening torque for the connecting terminals varies by model:

Model	Terminal Torque [Nm]	Battery Terminal Torque [Nm]
TriMOD 10-15-20	3.5	-
TriMOD 30TT	3.5	4.5
TriMOD 30/40TM	10	4.5
TriMOD 40TT-60	4.5	-
TriMOD 80	4.5	10

B = MAX 14,6mm
d = for M6 screws



When working with the TriMOD 10–15–20 kVA models, user-side connections should be made using:

Ring terminal lugs compatible with M6 screws, with a maximum overall width of 14.6 mm, suitable for cables of the appropriate cross-section.

For the selection of the required cable cross-section, refer to Table 1 – “Minimum Recommended Cable Cross-Sections” in Chapter 10 – Tables.

4. Installation

4.1.1 Wiring

For all the models, cables can be routed from underneath through the opening at the base of the unit.

For TriMOD models from 10 kVA to 60 kVA, cables can also be routed through a metal plate mounted on the rear panel, secured with four screws. In this case, cables must be secured using appropriate cable glands (not supplied), which should be inserted into the holes on the metal plate. The plate includes six holes with a diameter of 33 mm and one hole with a diameter of 16 mm:

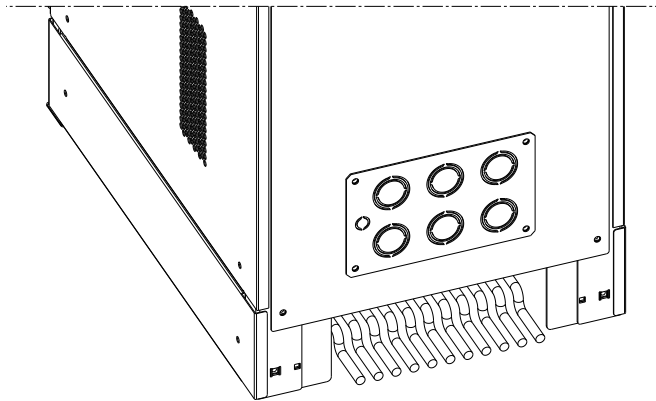

For the TriMOD 80 kVA model, cables must be routed exclusively through the base opening. Cable fastening is performed using the designated bar, with clamps and clips provided in one of the accessory packs.

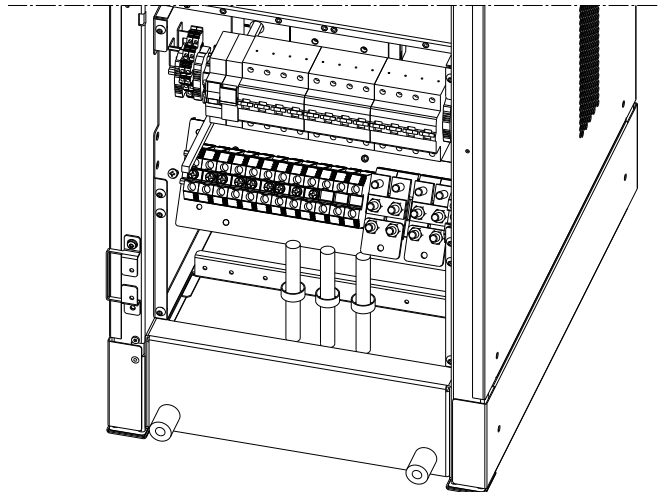

4.1.2 Earthing

Before performing any other installation steps, connect the earthing conductor from the low-voltage switchgear to the earthing terminal on the UPS terminal strip.

For the TriMOD 80 model, the earthing cables must be connected using cable lugs, secured in the 8 mm threaded holes located at the base of the unit, as shown in the following image:

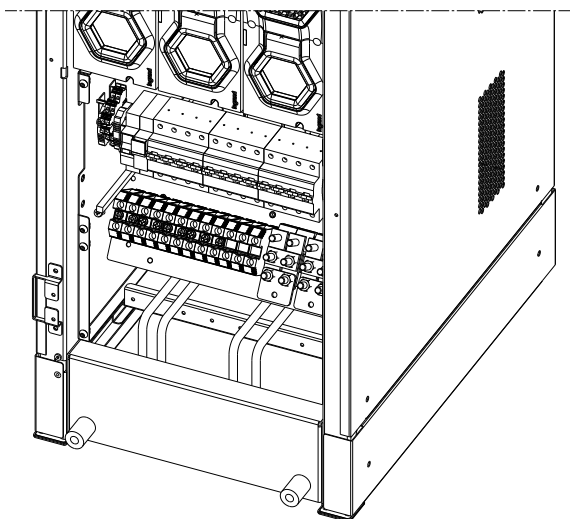

Use cables with a cross-section of at least 10 mm² for copper cables or 16 mm² for aluminum cables.

4.1.3 Protective Devices

To ensure proper protection against overloads and output short circuits, appropriate protective devices must be installed at the electrical system level.

Install automatic residual-current circuit breakers (RCCBs) and thermal-magnetic circuit breakers upstream of the UPS—on both the input line and the bypass line (if separate). These devices must be selected according to the specifications provided in the tables in Chapter 10.

4.1.4 Backfeed Protection

The TriMOD UPS is equipped with an auxiliary contact for activating external backfeed protection (i.e., protection against power flowing back toward the input). This auxiliary contact is implemented using a C/NC/NO relay and is available on the dedicated three-pole terminal labeled “BACKFEED PROTECTION” on the terminal strip.

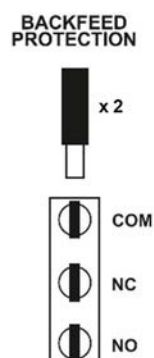

If the UPS detects a backfeed voltage, the relay is energized and changes state, enabling the disconnection of the input lines. This disconnection must be performed externally, as shown in the diagrams below.

Relay contact specifications:

- Maximum voltage: 250Vac.
- Maximum current: 5A ($\cos\phi = 1$)



If the UPS signals that the backfeed protection has been triggered during operation, contact Legrand Technical Support immediately.

4. Installation

Connection to a TT or TN-S distribution network and backfeed protection circuit diagrams with common input and bypass line

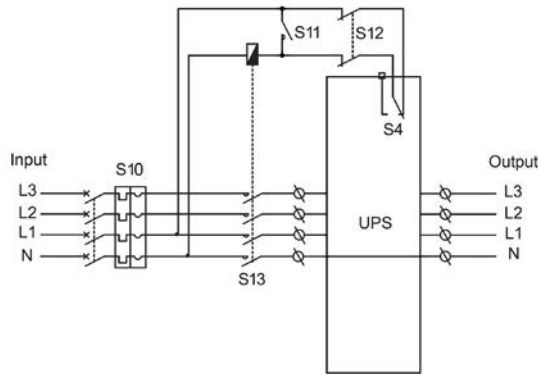

3-phase Input / 3-phase output configuration

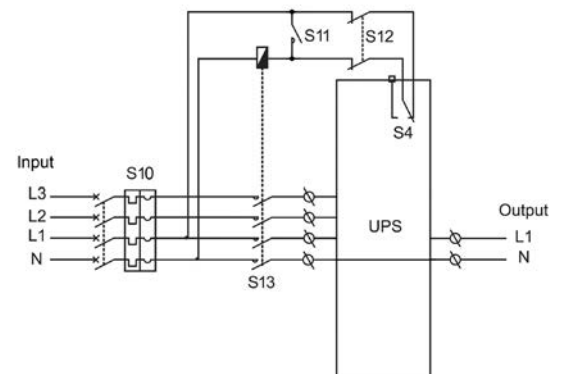

3-phase Input / 1-phase output configuration

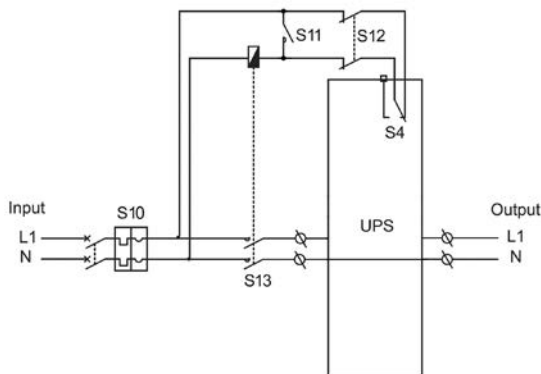

1-phase Input / 1-phase output configuration

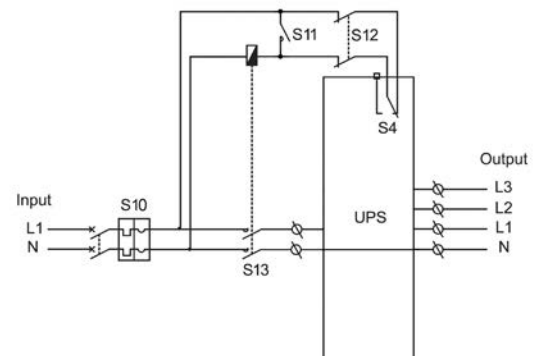

1-phase Input / 3-phase output configuration

S10: Thermal-magnetic/differential circuit breakers required on the input line.

S13: Contactor for opening the input line.

S11: Disconnector connected in parallel to the coil of contactor S13.

S12: Two-pole disconnector installed in series with the line leading to the EC9 connector on the contact interface card.

S4: Auxiliary contact for backfeed protection.

Connection to a TT or TN-S distribution network and backfeed protection circuit diagrams with separate input and bypass line

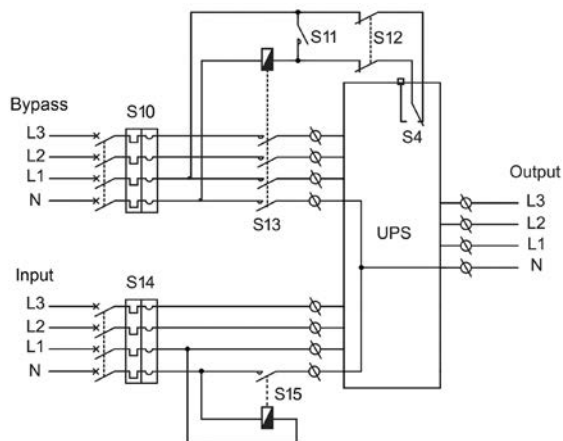

3-phase Input / 3-phase output configuration

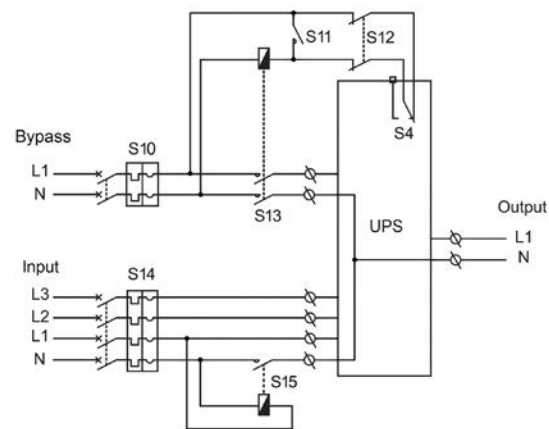

3-phase Input / 1-phase output configuration

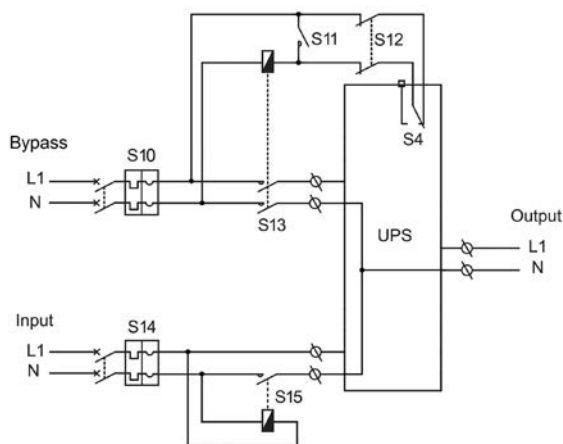

1-phase Input / 1-phase output configuration

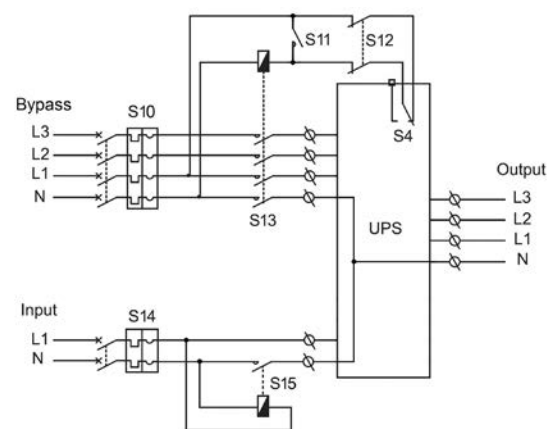

1-phase Input / 3-phase output configuration
(available only for 1-phase input and 3-phase independent output)

S10-S14: Thermal-magnetic/differential circuit breakers required on the input and bypass line.

S13: Contactor for opening the bypass line.

S15: Contactor for disconnecting the neutral of the network input line.

S11: Disconnector connected in parallel to the coil of contactor S13.

S12: Two-pole disconnector installed in series with the line leading to the EC9 connector on the contact interface card.

S4: Auxiliary contact for backfeed protection.

4. Installation

Connection to a TN-C distribution network and backfeed protection circuit diagrams with common input and bypass line

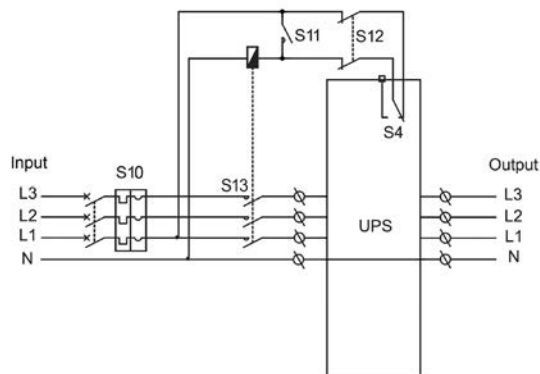

3-phase Input / 3-phase output configuration

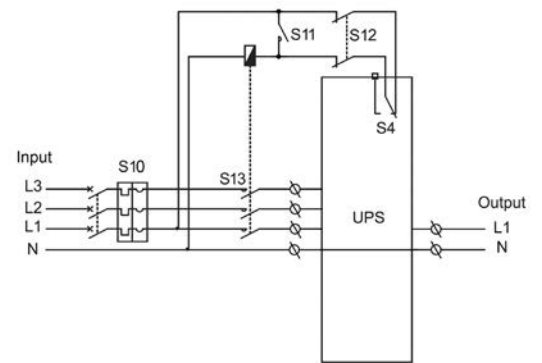

3-phase Input / 1-phase output configuration

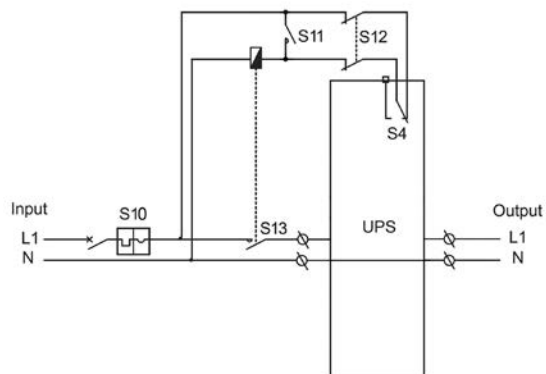

1-phase Input / 1-phase output configuration

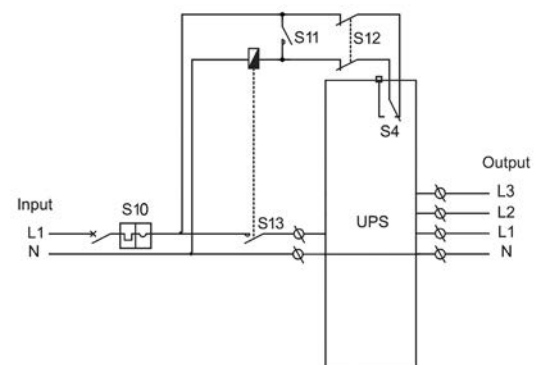

1-phase Input / 3-phase output configuration

S10: Thermal-magnetic/differential circuit breakers required on the input line.

S13: Contactor for opening the input line.

S11: Disconnector connected in parallel to the coil of contactor S13.

S12: Two-pole disconnector installed in series with the line leading to the EC9 connector on the contact interface card.

S4: Auxiliary contact for backfeed protection.

Connection to a TN-C distribution network and backfeed protection circuit diagrams with separate input and bypass line

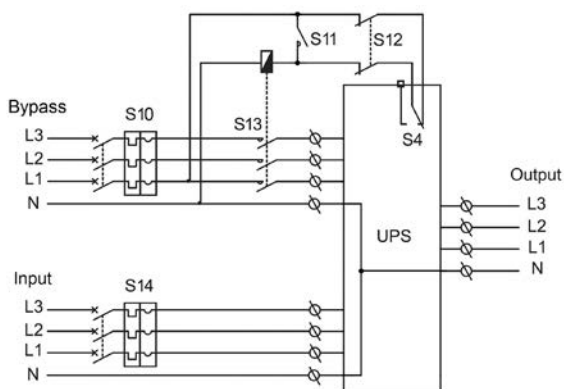

3-phase Input / 3-phase output configuration

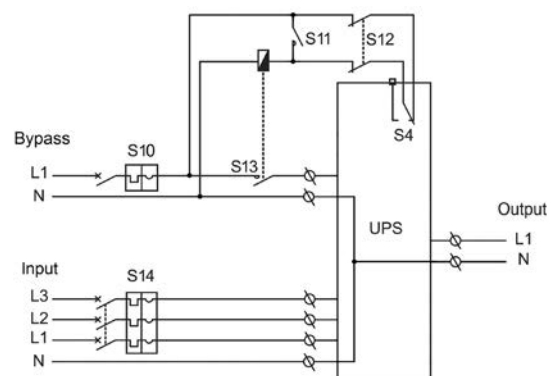

3-phase Input / 1-phase output configuration

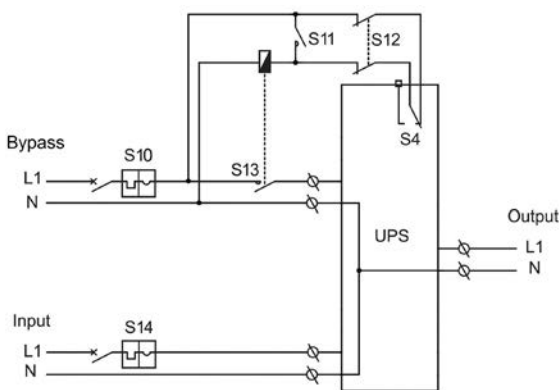

1-phase Input / 1-phase output configuration

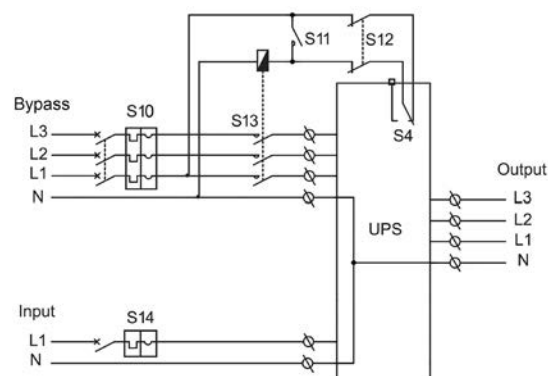

1-phase Input / 3-phase output configuration
(available only for 1-phase input and 3-phase independent output)

S10-S14: Thermal-magnetic/differential circuit breakers required on the input and bypass line.

S13: Contactor for opening the bypass line.

S11: Disconnector connected in parallel to the coil of contactor S13.

S12: Two-pole disconnector installed in series with the line leading to the EC9 connector on the contact interface card.

S4: Auxiliary contact for backfeed protection.

i By implementing external backfeed protection as shown in the diagrams, the input line can be safely disconnected and secured from outside the system. First, close disconnector S11, which is connected in parallel to the contactor coil. Then, open the two-pole disconnector S12, which is installed in series with the line leading to the EC9 connector.

4. Installation

4.1.5 External Battery Cabinets Installation

For UPS models without internal batteries, it is necessary to connect external battery cabinets. For models equipped with internal batteries, adding external battery cabinets increases the UPS's autonomy.



1 KB (Battery Kit) corresponds to a string of 20 batteries connected in series.

For models with internal battery drawers or external modular battery units, 1 KB consists of 4 battery drawers.

In modular cabinets with battery drawers, install 1 KB for every 10 kVA of nominal UPS power.

In non-modular external battery cabinets, each cabinet represents 1 KB. One KB is sufficient for all TriMOD models.

Example: for the TriMOD 40, at least one external modular battery cabinet with 4 KB (16 battery drawers) is required.

All models, except the TriMOD 30 TT, are equipped with dedicated terminals for connecting external batteries.

For the TriMOD 30 TT, external battery cabinets must be connected using plates mounted on the internal fuse holders located within the distribution terminal block, as illustrated in the figures below.

Use M6 screws to secure the eyelet terminals to the plates.

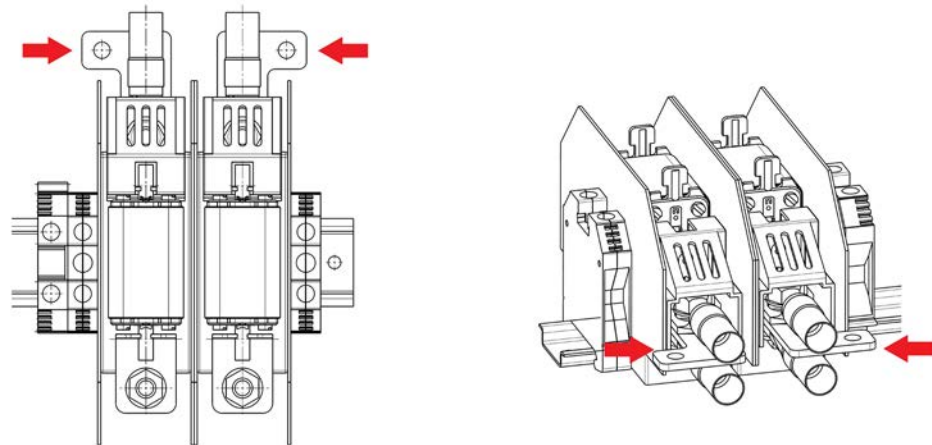

If the UPS is to be connected to one or more external battery cabinets, it is recommended to install a battery distribution board as illustrated below.

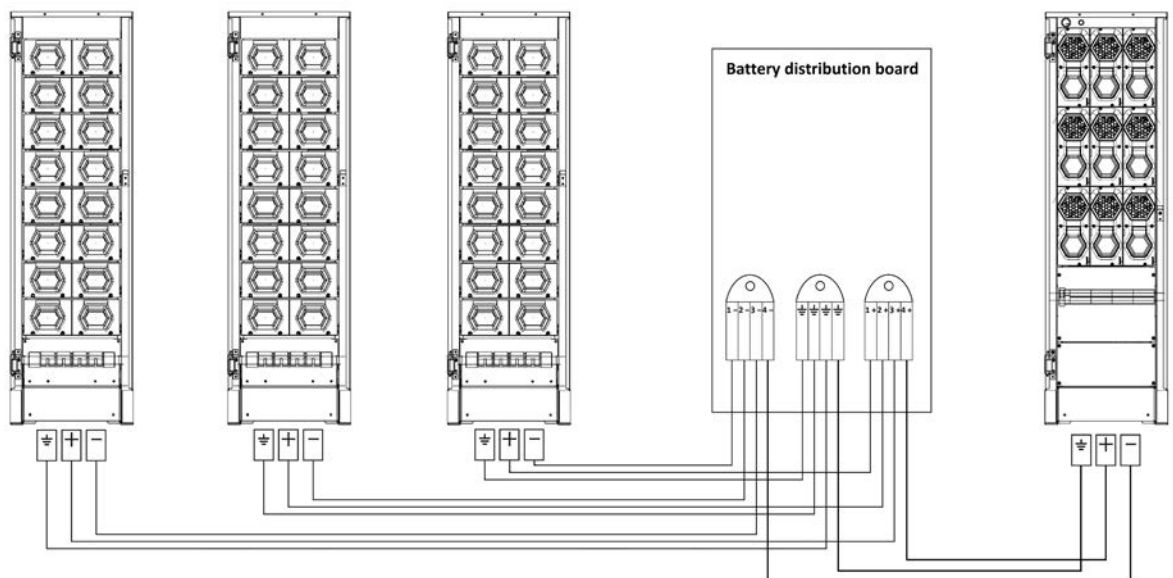

Modular external battery cabinets must be connected to the switchboard using the multipolar cables provided with the units. Non-modular external battery cabinets must be connected using external cables, following the specifications provided in Table 4 of Chapter 10.



Alternative connection methods are the sole responsibility of the installer. The battery switchboard must be implemented in compliance with local installation regulations, and its proper execution is the responsibility of the installer. The connection cable between the UPS and the battery switchboard must not exceed 3 meters in length. External modular battery cabinets must be homogeneous in the number of battery drawers. The difference between any two cabinets must not exceed 1 KB (equivalent to 4 battery drawers).



External modular battery cabinets cannot be connected to the TriMOD 80 model. Only non-modular external battery cabinets are compatible with this UPS.

4.1.5.1 Connection of One External Modular Battery Cabinet to the TriMOD 10-15-20-30TT/TM

One TriMOD modular battery cabinet (4KB or 5KB) can be connected to the TriMOD 10, 15, 20 or 30 TT/TM using one of the multipolar cables supplied with each battery cabinet.



The maximum length of the connection cable between the UPS and the battery cabinet must not exceed 3 meters.

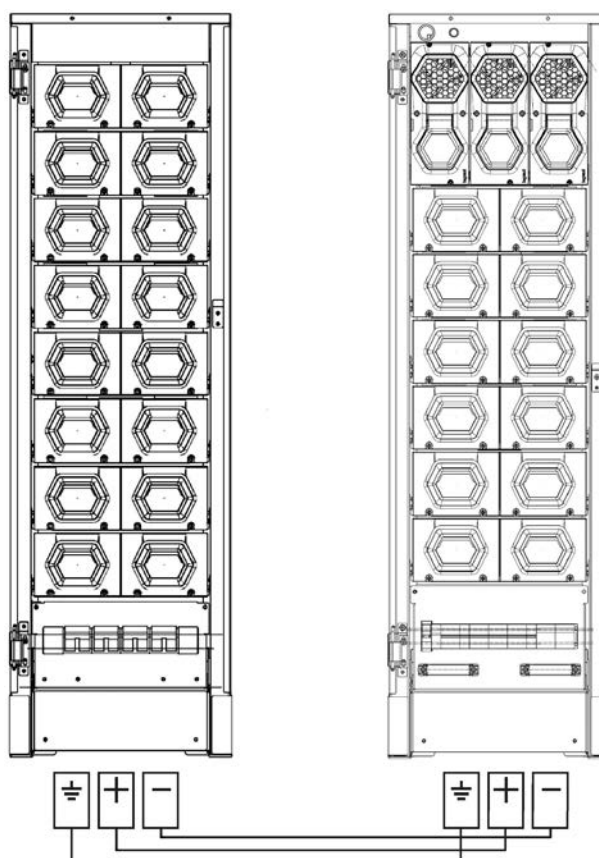

Follow the steps below to connect the external modular battery cabinet to the UPS:

1. Ensure all battery fuse disconnectors are open.
2. Loosen the screws securing the panel that provides access to the terminal strips of the external battery cabinet.
3. Using one of the supplied multipolar cables, connect the UPS to the external battery cabinet. Start by connecting the earthing wire (yellow-green).
4. Using the same multipolar cable, connect the positive and negative terminals of the UPS to the corresponding terminals on the external battery cabinet.
5. Reattach the panel and securely tighten the screws.

4. Installation

4.1.5.2 Connection of One External Modular Battery Cabinet to the TriMOD 40TT/TM

One TriMOD modular battery cabinet (4KB or 5KB) can be connected to the TriMOD 40 TT/TM with both multipolar cables supplied with each battery cabinet.

 The maximum length of the connection cable between the UPS and the battery cabinet must not exceed 3 meters.

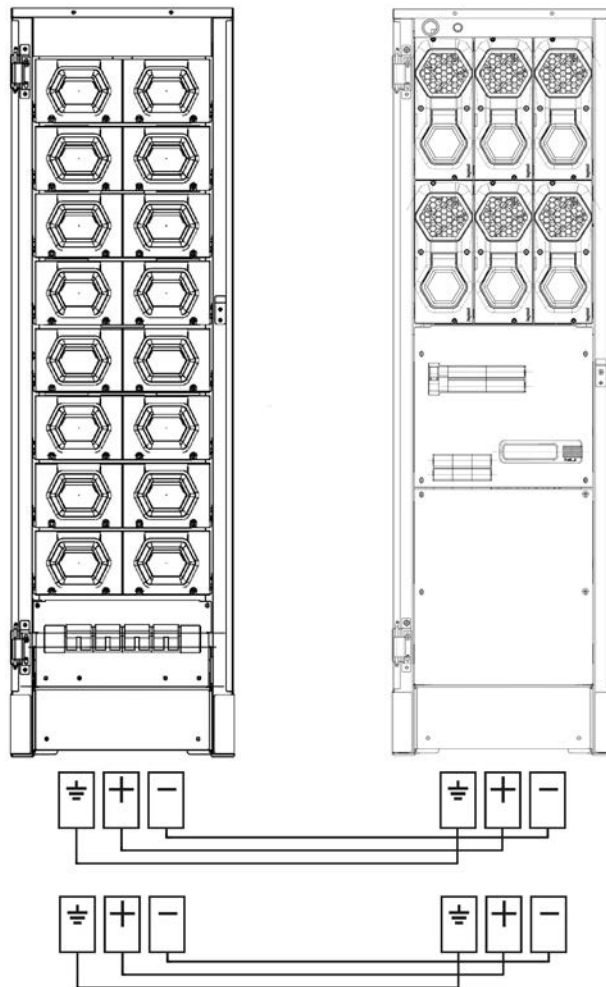

Follow the steps below to connect the external modular battery cabinet to the UPS:

1. Ensure all battery fuse disconnectors are open.
2. Loosen the screws securing the panel that provides access to the terminal strips of the external battery cabinet.
3. Using both of the supplied multipolar cables, connect the UPS to the external battery cabinet. Start by connecting the earthing wire (yellow-green).
4. Using the same multipolar cables, connect the positive and negative terminals of the UPS to the corresponding terminals on the external battery cabinet.
5. Reattach the panel and securely tighten the screws.

4.1.5.3 Connection of Two External Modular Battery Cabinets (5KB) to the TriMOD 60

The TriMOD 60 can only be connected to two TriMOD modular battery cabinet 5KB (20 battery drawers). This connection must be made exclusively using two external cables.

The multipolar cables supplied with each battery cabinet must be used only for the cascade connection between the first and second battery cabinets.

 The maximum length of the connection cable between the UPS and the first battery cabinet must not exceed 3 meters. It is not permitted to connect only one 5 KB modular battery cabinet. The external battery cabinets must be homogeneous in the number of battery drawers. The difference between any two cabinets must not exceed 1 KB (4 battery drawers).

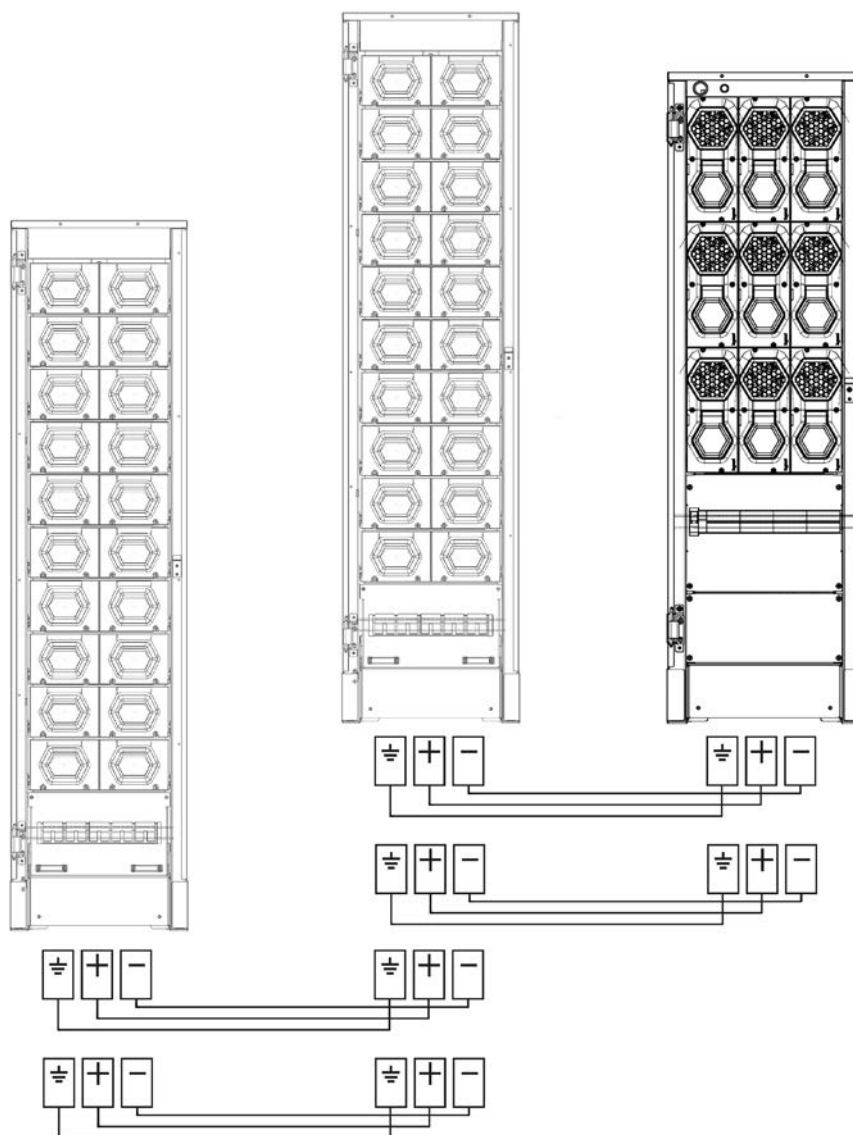

Follow the steps below to connect the two external modular battery cabinets to the UPS:

1. Ensure all battery fuse disconnectors are open.
2. Loosen the screws securing the panels that provides access to the terminal strips of the external battery cabinet.
3. Connect the UPS to the first external battery cabinet using an earthing cable (yellow-green).
4. Using two external cables connect the positive and negative terminals of the UPS to those of the first battery cabinet. Begin with the earthing wire.
5. Connect the first battery cabinet to the second using both multipolar cables provided. Start by connecting the earthing wire, followed by the positive and negative terminals.
6. Reattach the panels and securely tighten the screws.

4. Installation

4.1.6 Mains Connection

Before connecting the input power supply cables, ensure that all UPS switches are in the OFF position.

The default configuration is 3-phase input and 3-phase 120° output. If this configuration is used, the connection jumpers are already correctly sized and positioned. For alternative configurations, refer to paragraph 4.2 and Chapter 5.

Follow these steps to connect the mains:

1. Verify that the available mains power is equal to or greater than the nominal input power of the UPS.
2. Ensure that the cables to be connected to the UPS are isolated upstream and that no voltage is present.
3. Check that the earth wire from the low-voltage switchgear is connected to the correct terminal.
4. Connect the mains input neutral cable to the Nin terminal.
5. Connect the L1, L2, and L3 cables of the mains line to the respective L1in, L2in, and L3in terminals, ensuring the correct phase sequence (L1, L2, L3).



The neutral input wire must always be connected. Failure to do so may result in irreparable damage to the UPS when powered from the mains.

4.1.7 Bypass Input Line Connection (if Separate)

The default configuration uses a common bypass and input line.

However, a separate bypass line can be connected under the following conditions:

- The bypass and mains neutral wires must be electrically common.
- Both power supply lines (mains and bypass) must be protected by a single differential switch, if applicable.

To configure a separate bypass line, refer to paragraph 4.2 and Chapter 5.

Follow these steps to connect a separate bypass line:

1. Verify that the available mains power is equal to or greater than the nominal input power of the UPS.
2. Ensure that the bypass line cables are isolated upstream and that no voltage is present.
3. Connect the earth wire of the bypass line to the appropriate terminal at the bottom of the equipment.
4. Connect the bypass neutral wire to the Nby (bypass input neutral) terminal.
5. Remove the three jumpers linking terminals L1in, L2in, L3in with L1byp, L2byp, L3byp.
6. Connect the L1, L2, and L3 cables of the bypass input line to the respective L1byp, L2byp, and L3byp terminals, ensuring the correct phase sequence (L1, L2, L3).



The bypass neutral wire must always be connected. Failure to do so may result in irreparable damage to the UPS when powered from the mains.

4.1.8 Output Line Connection

Before connecting the loads, verify that the nominal power of the UPS, as indicated on the rating plate, is equal to or greater than the total power of the connected loads. The type and cross-section of the output cables must be selected based on their rated current and installation conditions, in accordance with applicable standards.

Provide a dedicated switchgear for the load. It is advisable to use circuit breakers or automatic switches compliant with IEC standards to protect the output lines.

Clearly label the system switchgear with the following information using stickers or equivalent signage:

- Maximum nominal power of the total load
- Maximum nominal power at each load outlet
- If a common switchgear is used for both mains and UPS power outlets, ensure that each outlet is labeled with its corresponding power source ("Mains" or "UPS")

The default configuration is 3-phase input and 3-phase 120° output. If this configuration is used, the connection jumpers are already correctly sized and positioned. For alternative configurations, refer to paragraph 4.2 and Chapter 5.

Follow these steps to connect the output line:

1. Ensure the UPS is turned off and that the output terminals are not live.
2. Connect the earth wire of the output line to the appropriate terminal.
3. Connect the output neutral wire to the Nout terminal.
4. Connect the L1, L2, and L3 cables of the output line to the respective L1out, L2out, and L3out terminals, ensuring the correct phase sequence (L1, L2, L3).

4.2 Wiring Diagrams

The electrical configuration must be completed on both the control panel and the distribution terminal strip.

 Always ensure that the connection jumper screws are properly tightened. If the factory configuration is modified, you must configure the new operating mode via the display, as described in Chapter 5.

4.2.1 Factory Configuration: 3-Phase Input – 3-Phase Output (with Common Bypass Input Line)

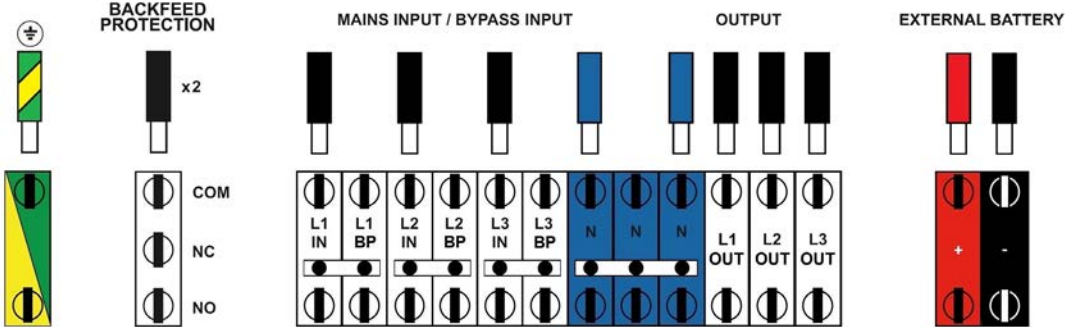

TriMOD 10- 15 - 20

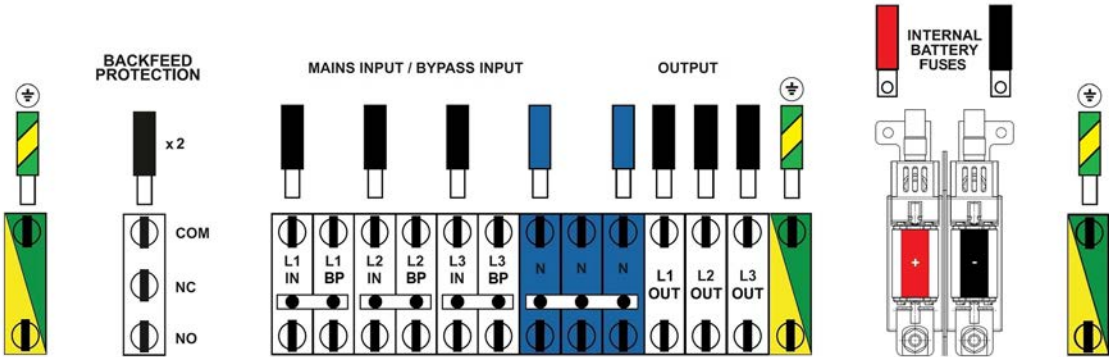

TriMOD 30 TT

4. Installation

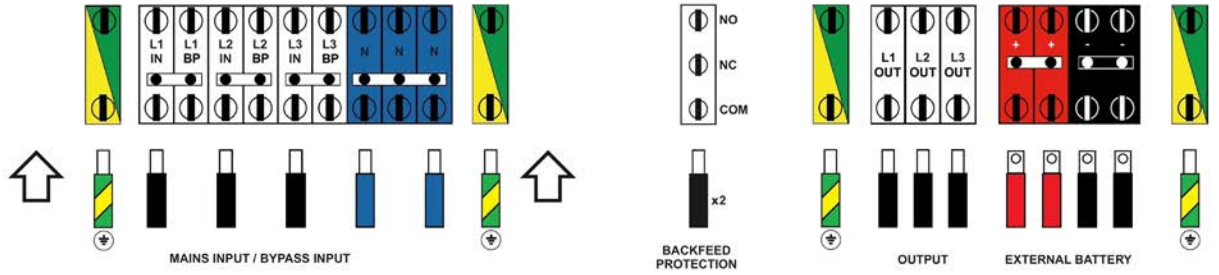

TriMOD 30-40 TM

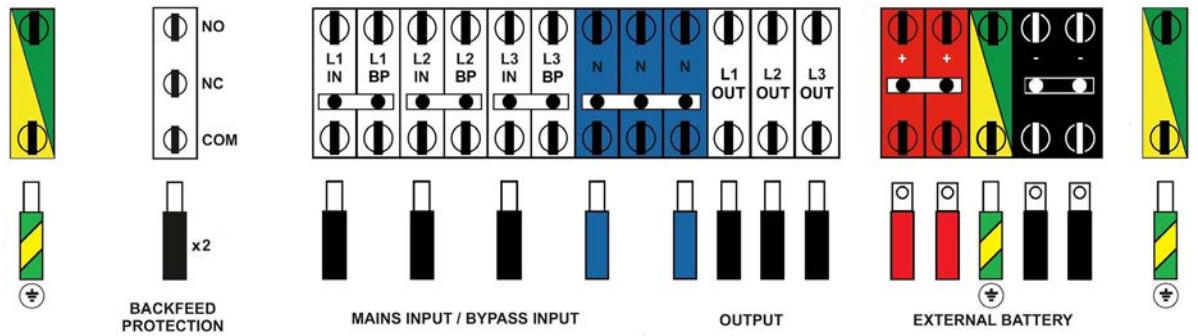

TriMOD 40 TT - 60

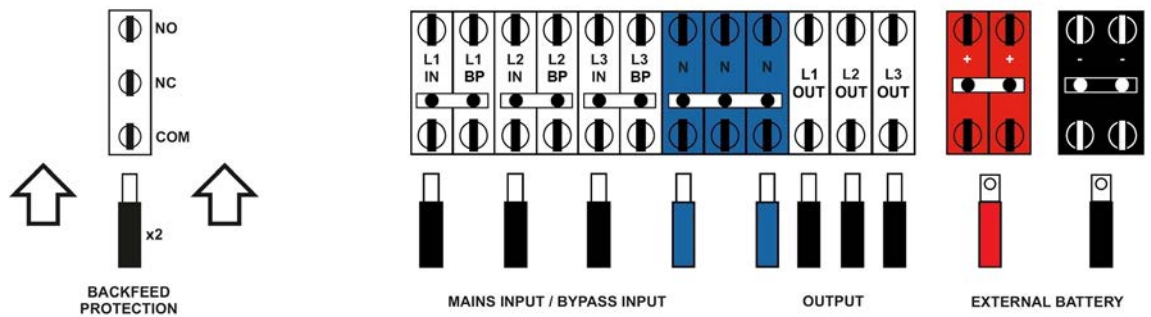

TriMOD 80

4.2.2 3-Phase Input – 3-Phase Output (with Separate Bypass Input Line)

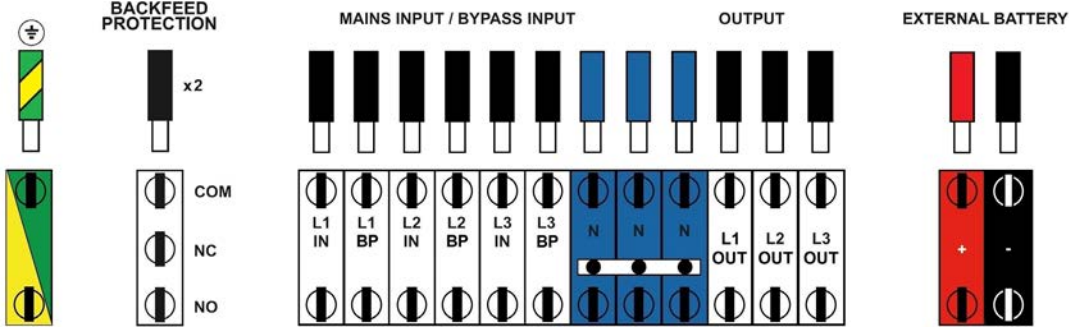

TriMOD 10 - 15 - 20

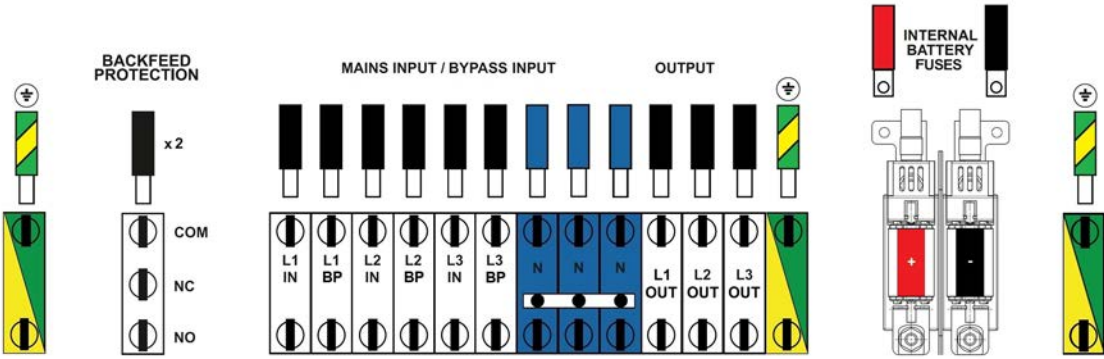

TriMOD 30 TT

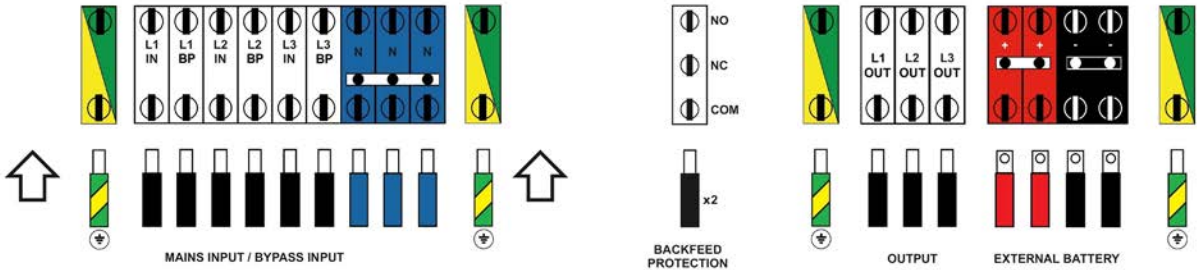

TriMOD 30-40 TM

4. Installation

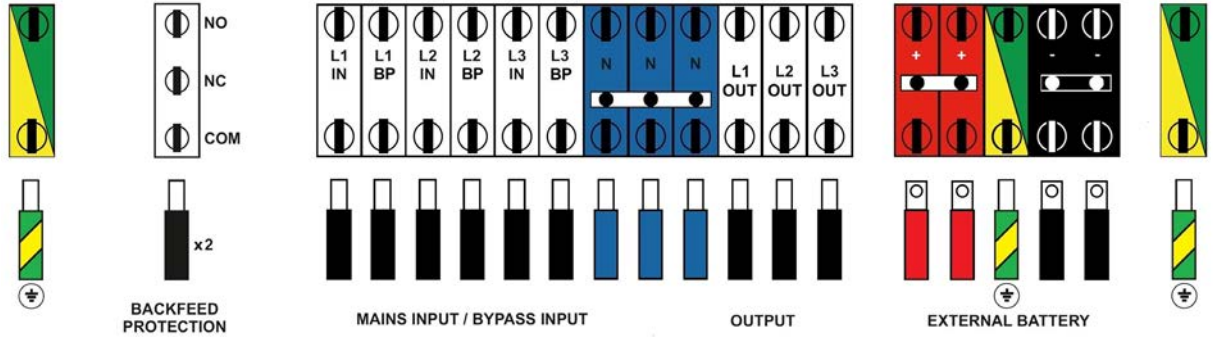

TriMOD 40 TT - 60

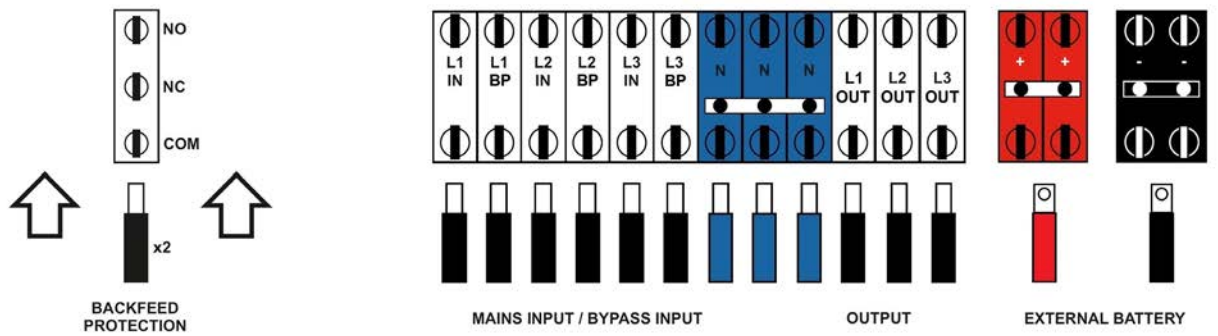

TriMOD 80

4.2.3 3-Phase Input – 1-Phase Output (with Common Bypass Input Line)

This configuration is available only for TriMOD 10, 15, 20, 30 and 40 TM models.

In addition to the wiring shown in the following images, it is necessary to configure the operating mode as illustrated in Chapter 5.

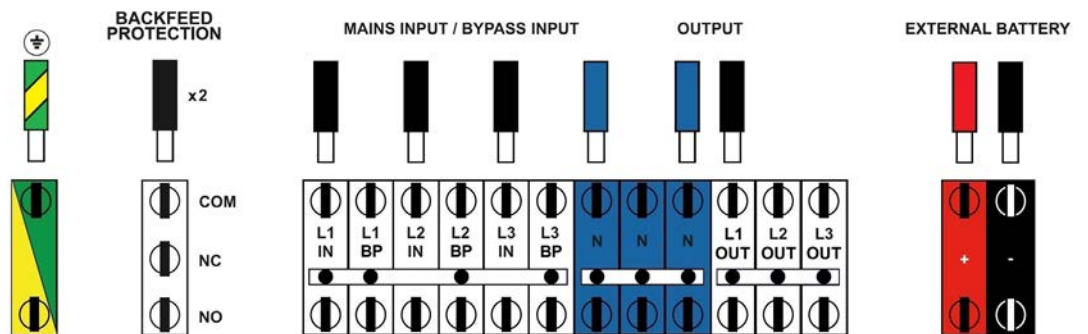

TriMOD 10 - 15 - 20

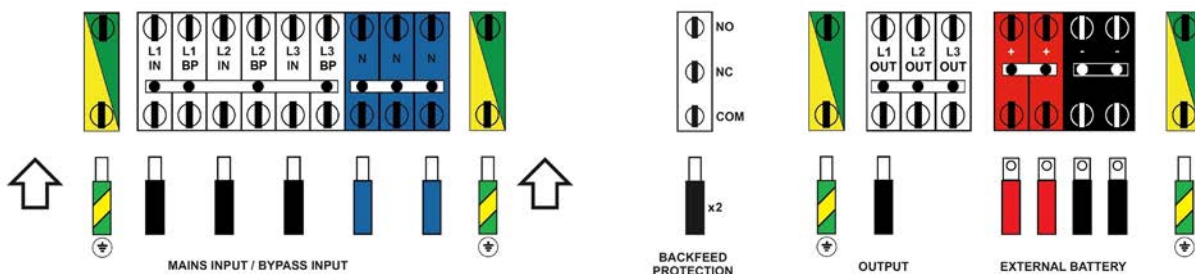

TriMOD 30-40 TM

Check the requirement at the end of par. 4.2.6 regarding all configurations with a 1-phase output

4.2.4 3-Phase Input – 1-Phase Output (with Separate Bypass Input Line)

This configuration is available only for TriMOD 10, 15, 20, 30 and 40 TM models.

In addition to the wiring shown in the following images, it is necessary to configure the operating mode as illustrated in Chapter 5.

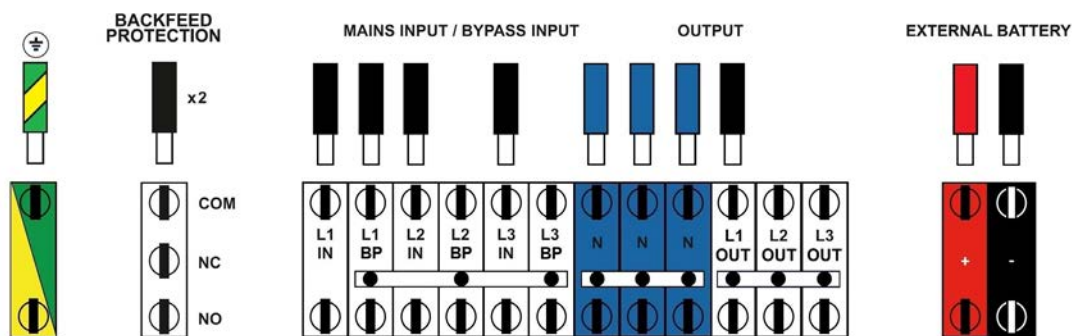

TriMOD 10 - 15 - 20

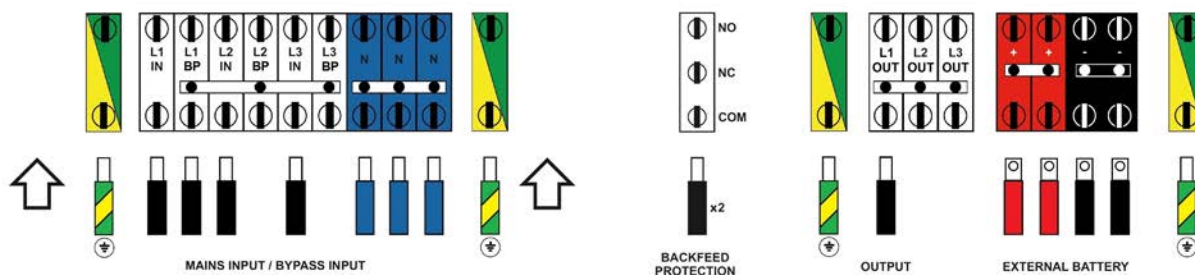

TriMOD 30-40 TM

Check the requirement at the end of par. 4.2.6 regarding all configurations with a 1-phase output

4. Installation

4.2.5 1-Phase Input – 1-Phase Output (with Common Bypass Input Line)

This configuration is available only for TriMOD 10, 15, 20, 30 and 40 TM models.

In addition to the wiring shown in the following images, it is necessary to configure the operating mode as illustrated in Chapter 5.

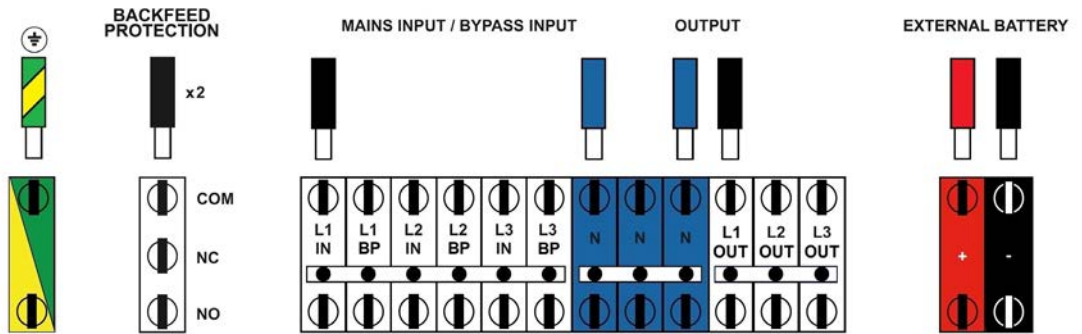

TriMOD 10 - 15 - 20

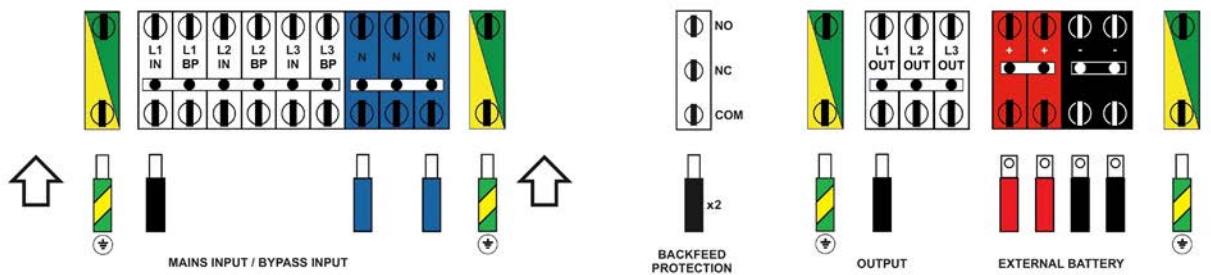

TriMOD 30-40 TM



Check the requirement at the end of par. 4.2.6 regarding all configurations with a 1-phase output

4.2.6 1-Phase Input – 1-Phase Output (with Separate Bypass Input Line)

This configuration is available only for TriMOD 10, 15, 20, 30 and 40 TM models.

In addition to the wiring shown in the following images, it is necessary to configure the operating mode as illustrated in Chapter 5.

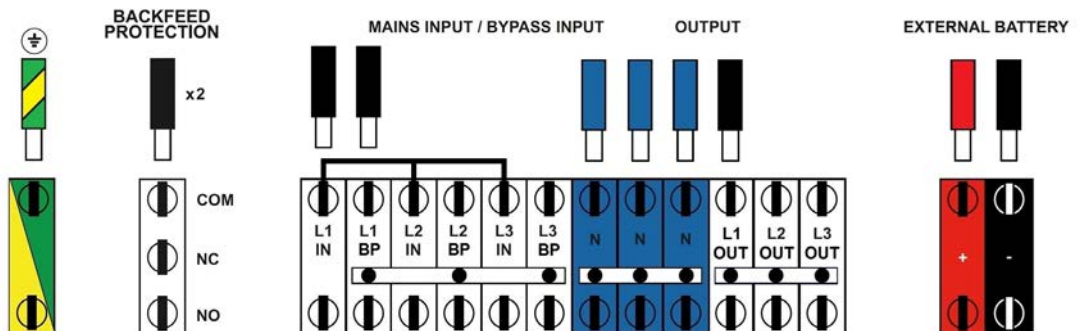

TriMOD 10 - 15 - 20

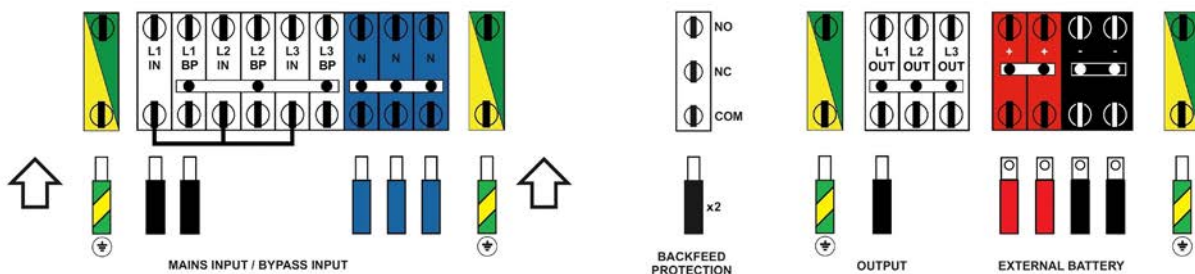

TriMOD 30-40 TM

i For all the configurations with a 1-phase output (par. 4.2.3 to 4.2.6), it is necessary to insert a special connector, provided in the accessory kit, into all the back panel boards. The back panel boards are located behind the power modules within the equipment. TriMOD 10, 15 and 20 have just 1 back panel board. TriMOD 30-40 TM have 2 back panel boards. The connector must be inserted in the position marked "EC 15" on the board, as shown in the following figure:

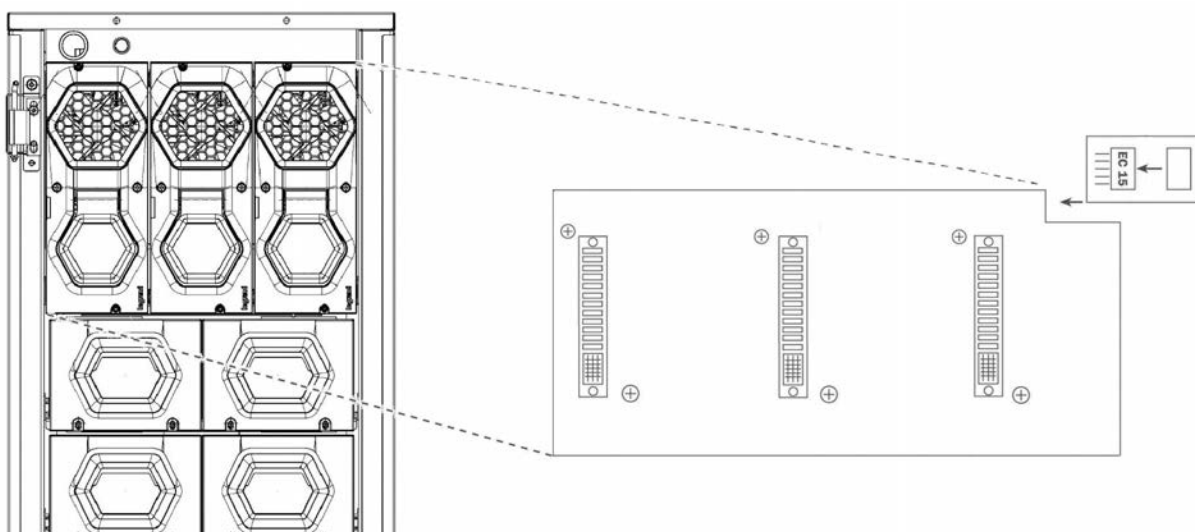

4. Installation

4.2.7 1-Phase Input – 3-Phase Output 120°

This configuration is available only for TriMOD 10, 15, 20, 30 and 40 TM models.

In addition to the wiring shown in the following images, it is necessary to configure the operating mode as illustrated in Chapter 5.

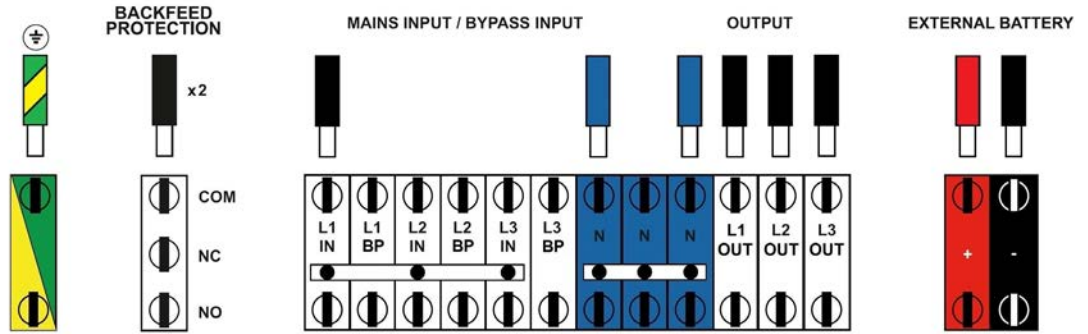

TriMOD 10 - 15 - 20

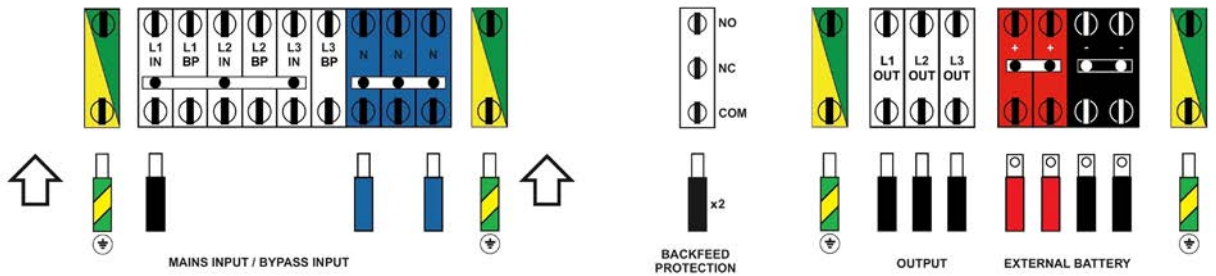

TriMOD 30-40 TM



The bypass function is not available for this configuration.

The manual maintenance bypass breaker and bypass input line breaker must never be activated. For greater safety, eliminate the manual maintenance bypass by cutting the brown, black, and grey wires that connect the maintenance breaker to the output breaker, ensuring the wires are adequately isolated.

4.2.8 Installation of the Connection Jumpers for TriMOD 10-15-20 kVA

1. Take one of the connection jumpers out of the accessory envelope and cut it to the required length. Ensure that no burrs remain after cutting, as these could cause contact with adjacent jumpers.

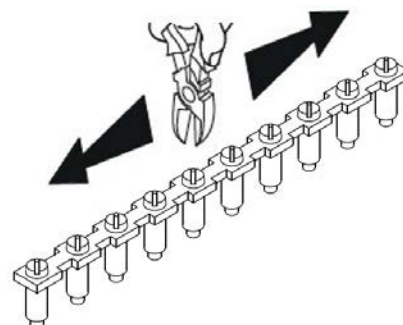

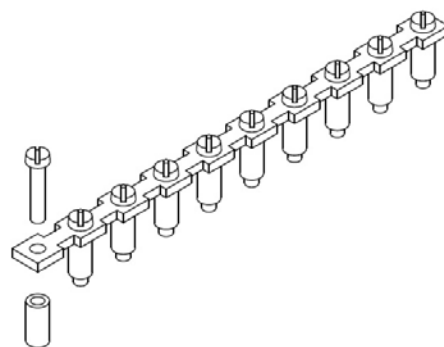

2. Remove any vertical connections that are not shown in the connection diagrams.

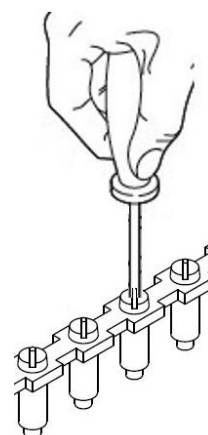

3. Insert the jumper into the terminal strip as indicated in the connection diagrams.

4. Carefully tighten all the screws on the terminal strip firmly.



 For configurations with single-phase input and single-phase output using a separated bypass (see par. 4.2.6), a special “E”-shaped connector—provided in the accessory kit—must be used.

4. Installation

4.2.9 Installation of the Connection Jumpers for TriMOD 30-40-60-80 kVA

1. Take one of the connection jumpers out of the accessory envelope and cut it to the required length. Ensure that no burrs remain after cutting, as these could cause contact with adjacent jumpers.

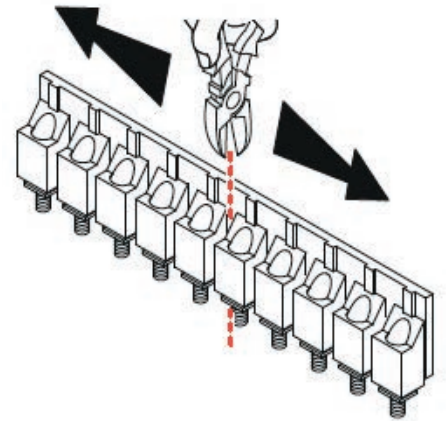

2. Remove any vertical connections that are not shown in the connection diagrams.

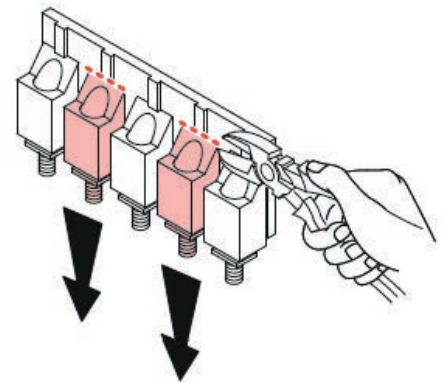

3. Insert the jumper into the terminal strip as indicated in the connection diagrams.

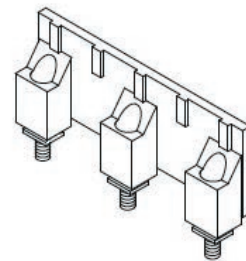

4. Carefully tighten all the screws on the terminal strip.

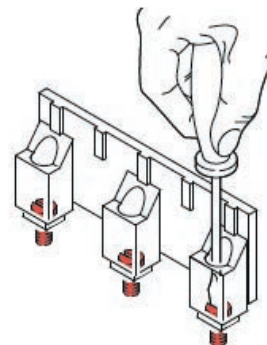

5. Secure the terminal strip firmly.

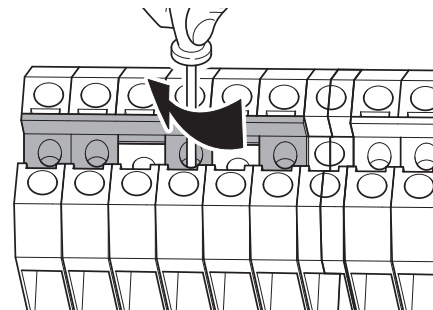

6. Use a screwdriver to extract the yellow plastic part.

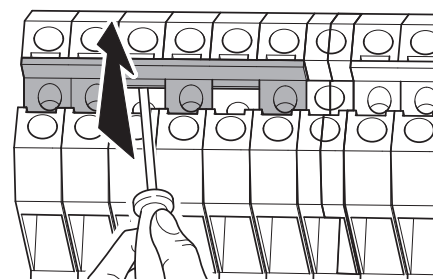

7. Check that the screw heads are properly seated on the terminals.

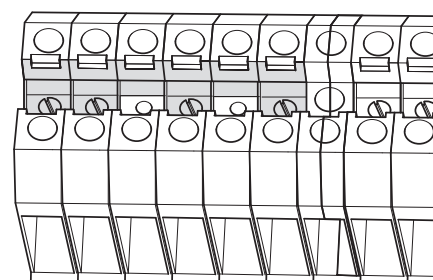

8. Reinsert the yellow plastic part.

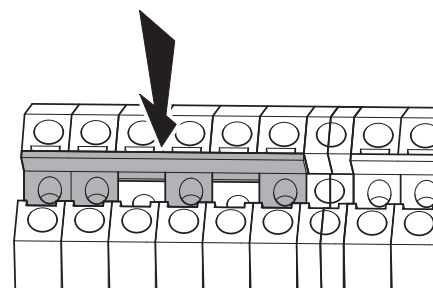

4. Installation

4.2.10 Parallel System

Up to 24 power modules and 8 control boards can be connected in parallel to support system redundancy. All UPS units in the parallel configuration must be of the same model (e.g., TriMOD 60 kVA units can only be connected in parallel with other TriMOD 60 kVA units).

The maximum load capacity supported by a parallel configuration is the same as that of a single unit. However, if one UPS becomes inoperable, the remaining units will continue to supply the load without interruption.

To configure the parallel system, the first step is to set the ID address of each UPS using the rotary switch located on the rear panel.

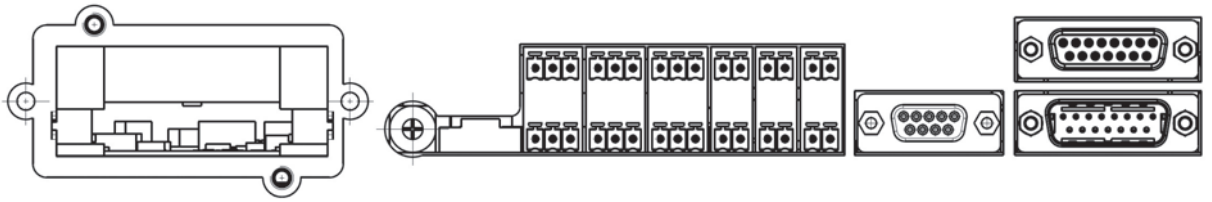

The UPS with the lower address is the master. For example, in a parallel system with three UPS units, assign the following ID addresses using the rotary switch:

UPS 1: ID = 0

UPS 2: ID = 1

UPS 3: ID = 2

Each UPS must have a unique ID to ensure proper communication and coordination within the parallel system.

In the parallel kit 3 113 29, two cables are required to connect the parallel ports of the UPS units. One is a 15-pin straight-through cable, and the other is a 15-pin termination (or closing) cable. These cables are essential for enabling communication and synchronization between the units in a parallel configuration.

The cables have the following specifications:

15-pin straight-through cable

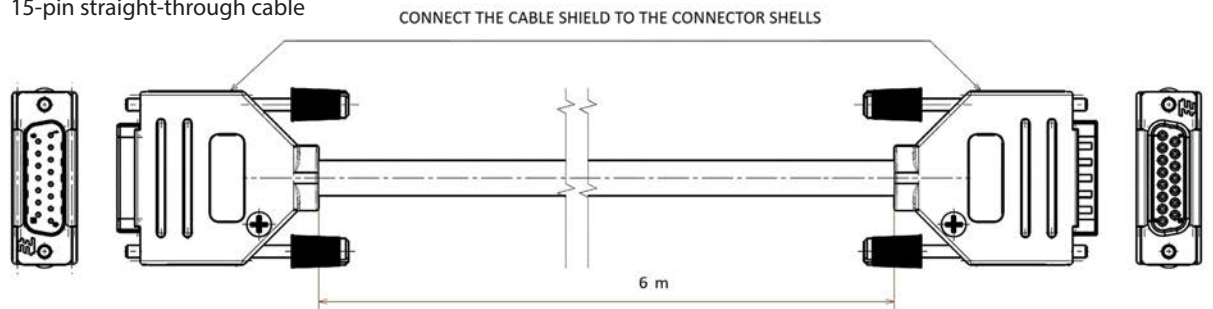

WIRING DIAGRAM

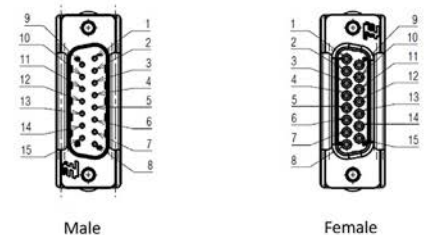
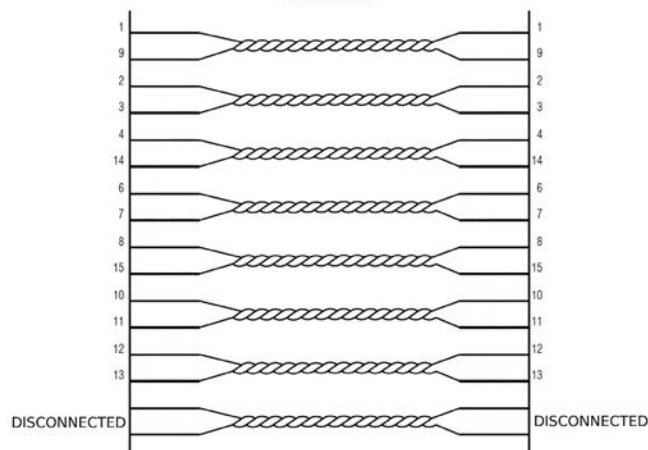

Left Side (Pin)	Color	Right Side (Pin)	Color
1	White	1	White
9	Brown	9	Brown
2	Green	2	Green
3	Yellow	3	Yellow
4	Gray	4	Gray
14	Pink	14	Pink
6	Blue	6	Blue
7	Red	7	Red
8	Black	8	Black
15	Violet	15	Violet
10	Gray-pink	10	Gray-pink
11	Red-blue	11	Red-blue
12	White-green	12 <td White-green	
13	Brown-green	13	Brown-green
	White-Yellow	DISCONNECTED	White-Yellow
	Yellow-Brown	DISCONNECTED	Yellow-Brown

15-pin termination cable

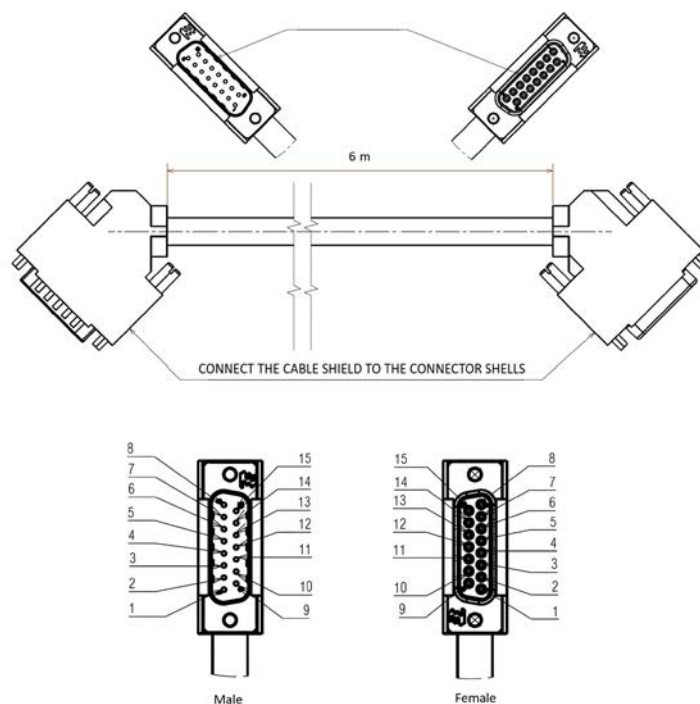
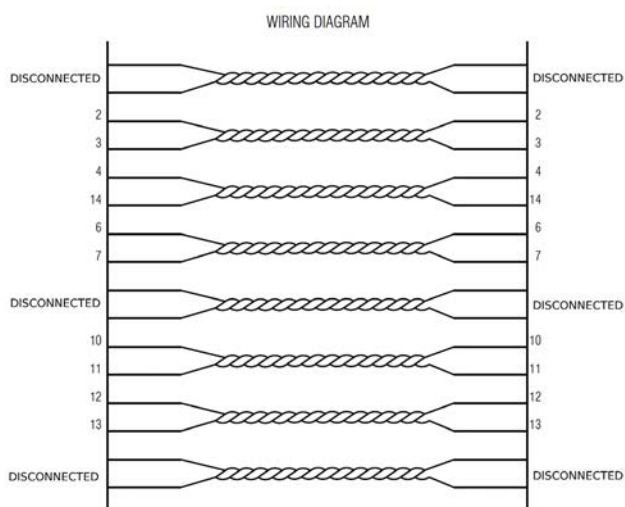

Left Side (Pin)	Color	Right Side (Pin)	Color
DISCONNECTED	White	White	DISCONNECTED
DISCONNECTED	Brown	Brown	DISCONNECTED
2	Green	Green	2
3	Yellow	Yellow	3
4	Gray	Gray	4
14	Pink	Pink	14
6	Blue	Blue	6
7	Red	Red	7
DISCONNECTED	Black	Black	DISCONNECTED
DISCONNECTED	Violet	Violet	DISCONNECTED
10	Gray-Pink	Gray-Pink	10
11	Red-Blue	Red-Blue	11
12	White-Green	White-Green	12
13	Brown-Green	Brown-Green	13
DISCONNECTED	White-Yellow	White-Yellow	DISCONNECTED
DISCONNECTED	Yellow-Brown	Yellow-Brown	DISCONNECTED

To establish communication between UPS units in a parallel configuration, connect the parallel ports on the rear panels of the units using the 15-pin straight-through cable. Complete the loop between the first unit and the last unit by installing the 15-pin termination cable.

4. Installation

2 units in parallel

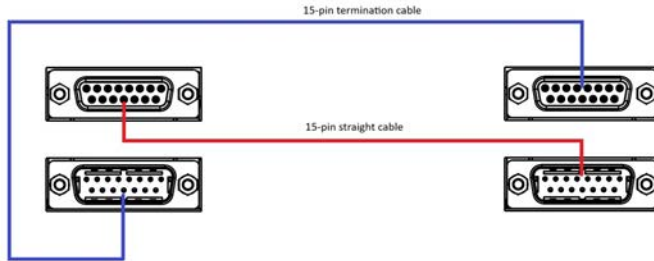

3 units in parallel

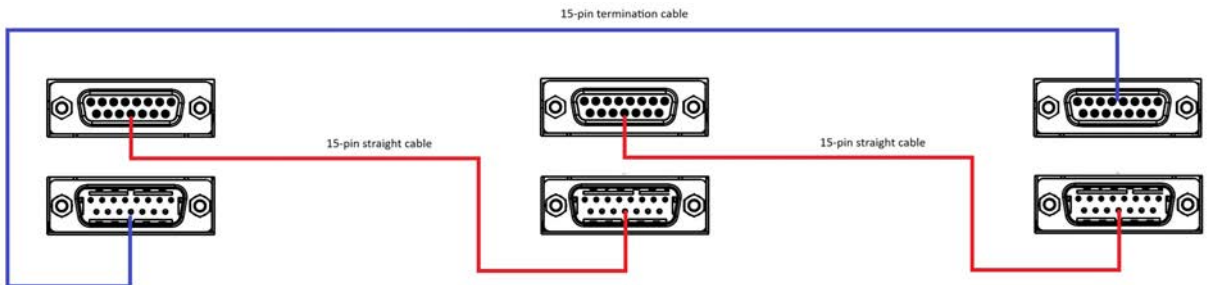

Open the top cover of each UPS unit to configure correctly the dip switch located on the connector board.

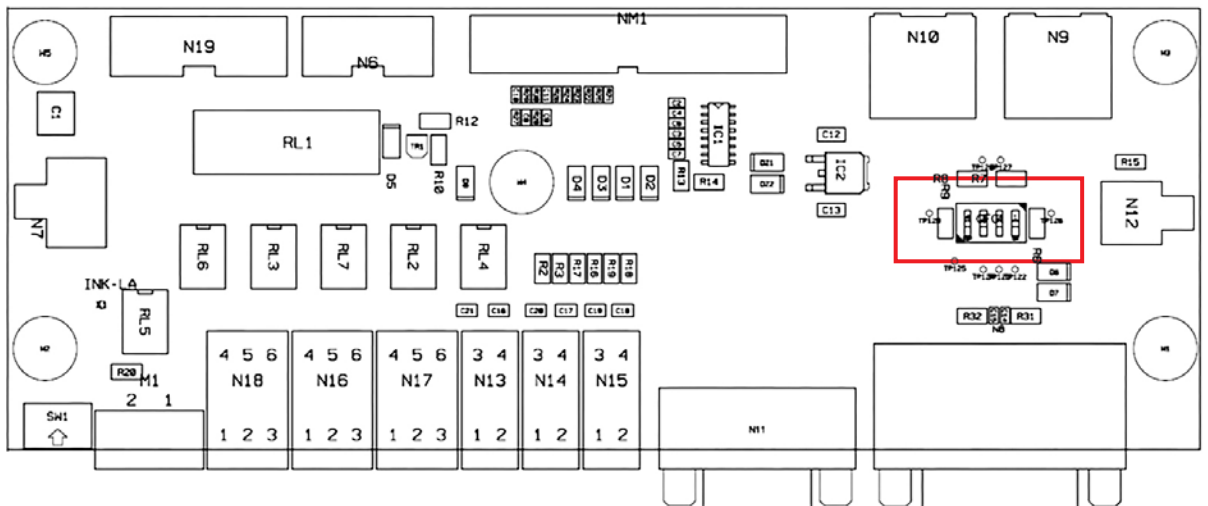

The DIP switch on the connector PCB is configured as follows:
 Contacts 1–2 correspond to the parallel male connector.
 Contacts 3–4 correspond to the parallel female connector.



By default, all DIP switch contacts are set to the ON position.

For each parallel port where a 15-pin straight-through cable is connected, the corresponding DIP switch contacts must be set to the OFF position.

If the straight-through cable is connected to the male parallel port, set contacts 1–2 to OFF. If it is connected to the female parallel port, set contacts 3–4 to OFF.

2 units in parallel

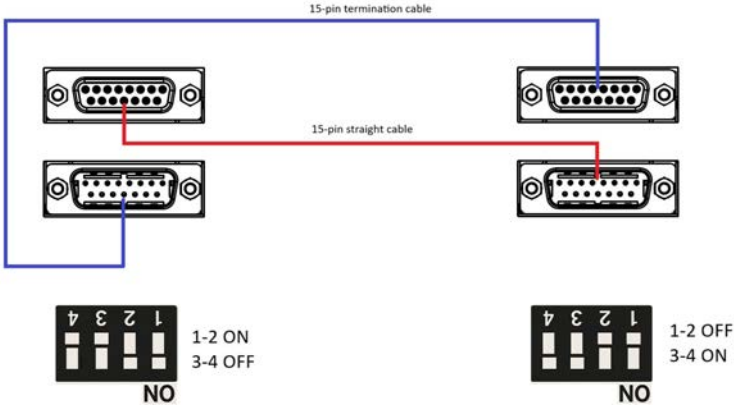

3 units in parallel

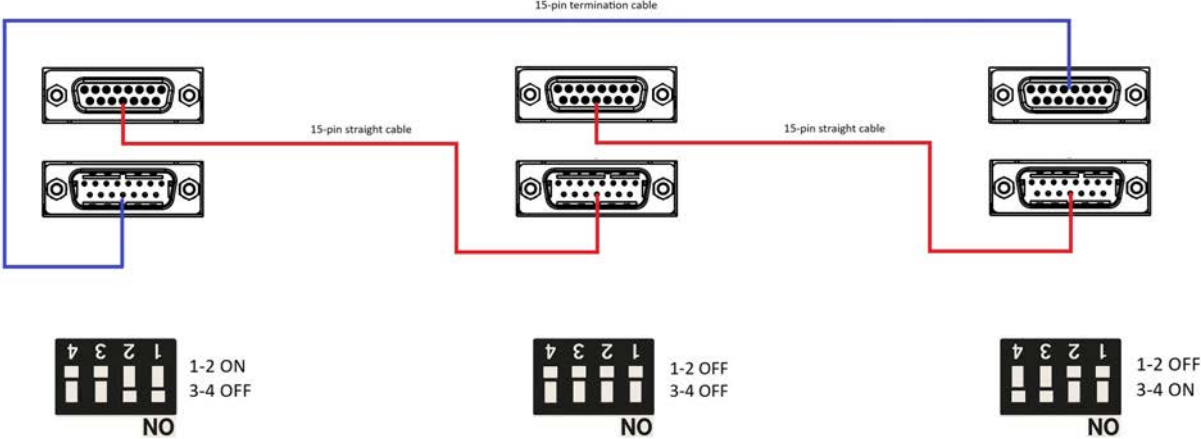

No configuration is required via the UPS display panel.

4. Installation

For the installation of the cables for the parallel system, it is recommended to provide an external system bypass as indicated in the following connection diagram:

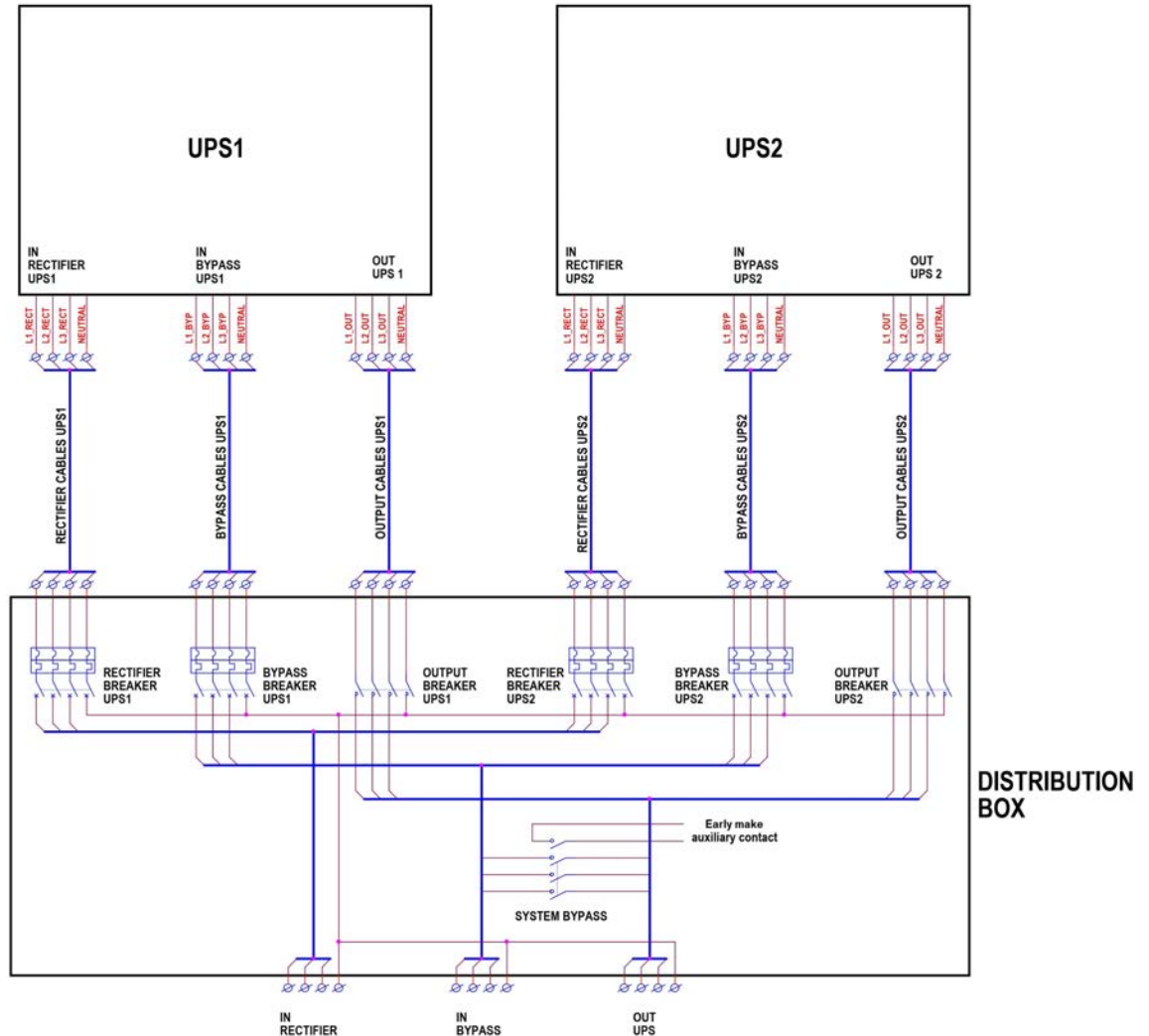

Follow these steps:

- connect the PE (Protective Earth) between the UPS units to ensure an equipotential bonding.
- connect the input line and the bypass line (including the earthing cable) of the mains to the distribution box where it is also present the external system bypass.
- connect the load to the output line of the distribution box.
- connect the input cables for each UPS (see paragraph 4.1.6) to the input line of the distribution box.
- connect the bypass cables for each UPS (see paragraph 4.1.7) to the bypass line of the distribution box. These cables must have the same length and the same cross section.
- connect the output cables for each UPS (see paragraph 4.1.8) to the output line of the distribution box. These cables must have the same length and the same cross section.

Use only the external system bypass for maintenance and block the maintenance bypass of each single UPS unit to 0 (open). An early make contact of the external maintenance bypass must be connected to the MAINT BYP terminal of the contacts interface of all UPS units (all pin 1 together, all pin 2 together) of the parallel system (see paragraph 4.4.3).

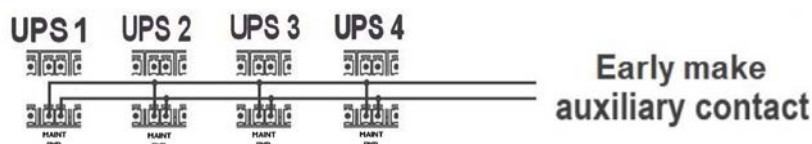

The following diagram indicates how to connect battery cabinets to a parallel system:

Separate battery cabinet

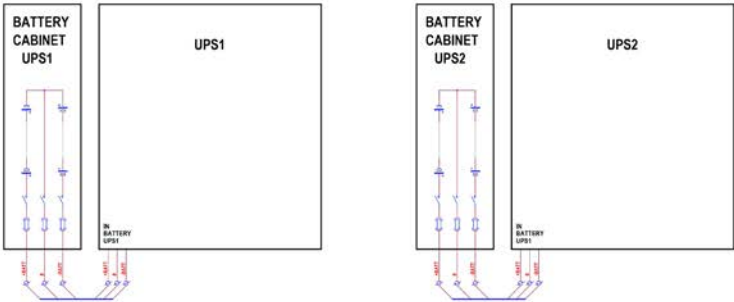

Common battery cabinet

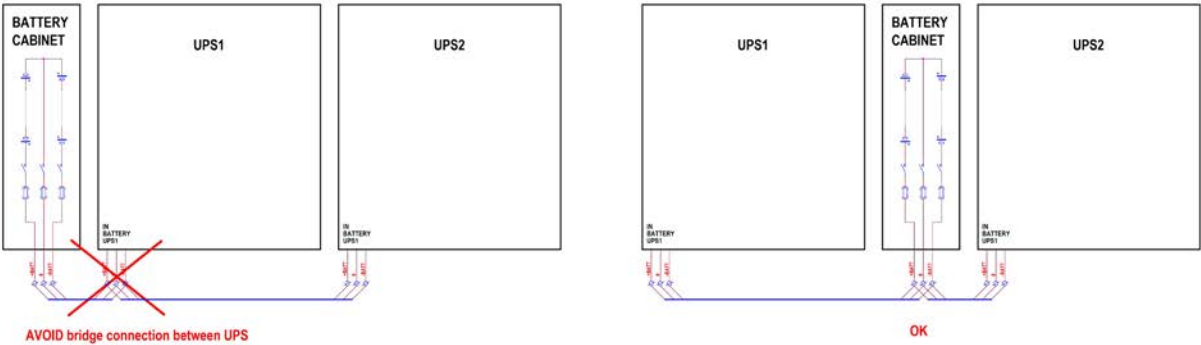

4. Installation

4.3 Insertion of Power Modules and Battery Drawers

Once all the electrical connections have been completed, close the distribution drawer for the TriMOD 10, 15, 20, 30 TT models or securely fasten the lower panels with screws for the TriMOD 30 TM, 40 TM, 40 TT, 60 and 80.

You can then proceed with inserting the power modules and battery drawers into the UPS (depending on the model) and into any external modular battery cabinets, if present.



TriMOD UPS units have electrical distribution sized for the nominal power of the equipment and must be used only with the power modules provided, as specified in the "Mechanical characteristics" table in Chapter 9 of this manual. Do not use power modules other than those specified. Do not swap or replace modules to alter the UPS power rating. The model, nominal power, and type of power module to be installed are indicated in the installation manual and on the rating plate inside the UPS door. The type and nominal power of each power module are also shown on a rating plate of the module.

When installing power modules, begin from the top of the cabinet with the lowest address. In three-phase configurations, always complete sets of three PMs per level.

Insert the power modules one at a time, ensuring they are fully seated. Secure each module to the frame using the two SHC M4x20 screws (hex socket head) provided. These screws also serve as the module's earth connection and must be installed for safety.



If one or more power modules are not installed, cover the empty slots using the plastic covers from kit 3 108 66. Each cover must be secured with two SHC M4x20 screws.

Insert the battery drawers one at a time, ensuring they are fully seated. For each drawer, tighten all the provided SHC M4x20 screws.



For the TriMOD 30 TT, do not insert the drawers fully or fasten them with screws.



If one or more battery drawers are not installed, cover the empty slots using the plastic covers from kit 3 108 65. Each cover must be secured with two SHC M4x20 screws.

4.4 Communication Interfaces

The TriMOD UPS is equipped with a series of communication interfaces located on the rear panel.



- For operator safety, all communication interfaces must be connected in compliance with the following requirements:
- The maximum voltage between any two connected wires, or between any wire and earth, must not exceed 42 V peak or 60 V DC;
 - The isolation voltage between any connected wire and earth must be at least 1500 V AC.

4.4.1 Serial Communication Port

The RS232 serial port is located on the rear panel of the UPS. This interface provides access to key operational data.

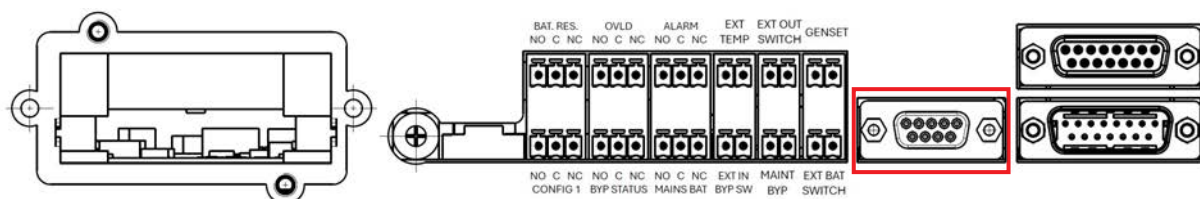

4.4.2 Emergency Power Off (EPO)

The UPS is equipped with an external Emergency Power Off (EPO) input, which allows for the immediate shutdown of the system. The default configuration is NO (Normally Open). The EPO terminal is located on the rear panel of the UPS, as shown in the illustration below:

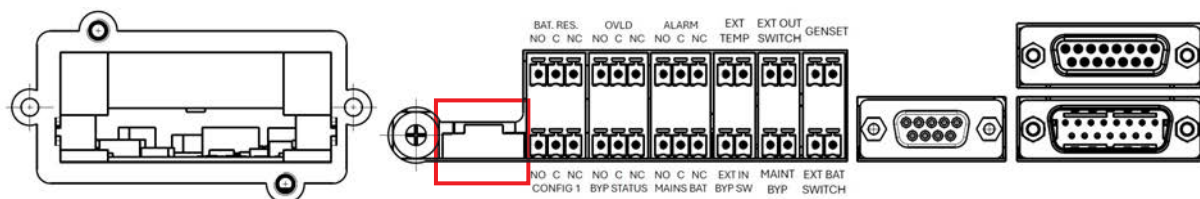

To ensure proper and safe connection of the EPO circuit, the following requirements must be met:

- Use a double-insulated cable with a maximum length of 10 meters.
- Ensure that the switch used is galvanically isolated from other circuits.

4. Installation

The electrical characteristics of the EPO interface are as follows:

- Open-circuit voltage: 12 V DC
- Closed-circuit current: 5 mA

The diagram below illustrates the correct method for connecting the EPO circuit:

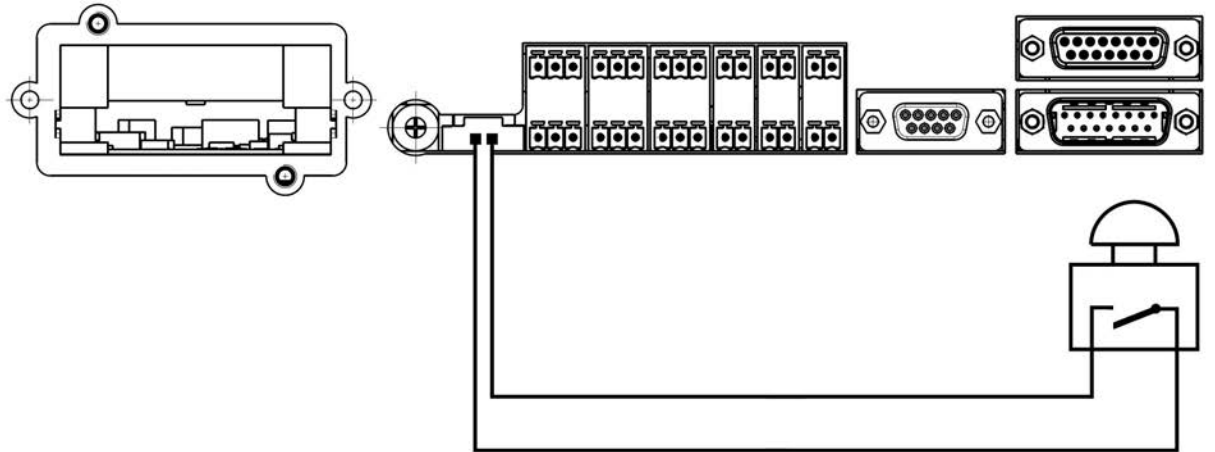

The diagram below illustrates the correct method for connecting the EPO circuit with multiple UPS devices in parallel:

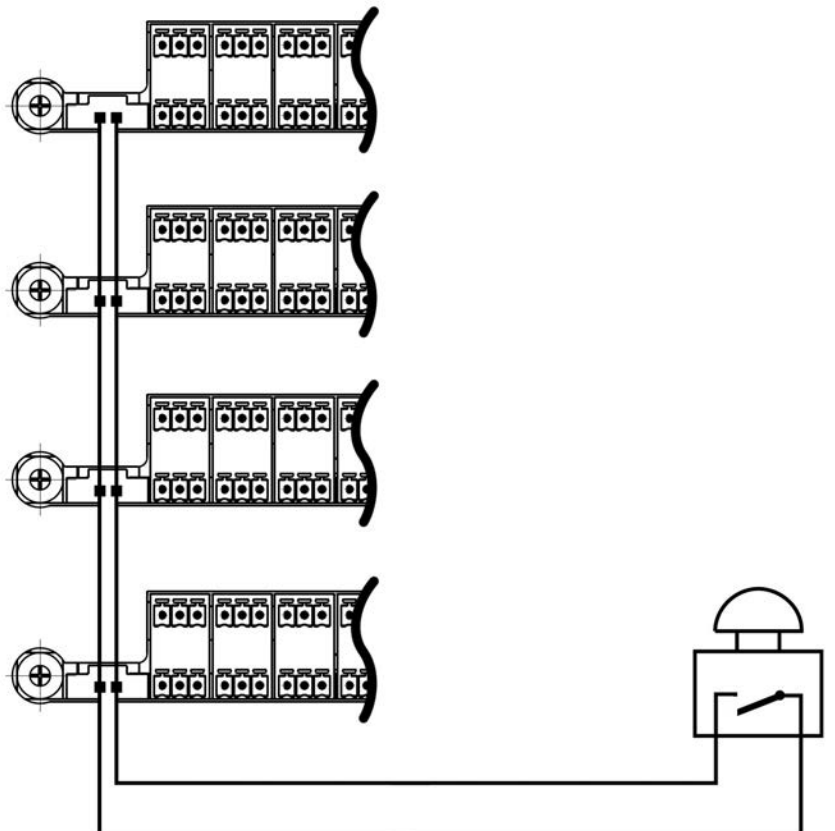

4.4.3 Input and Output Contacts

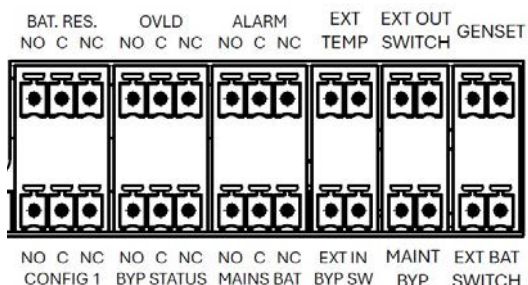

	TERMINAL	PINS	FUNCTION	
Output contacts	BAT. RES.	NO-C-NO	BATTERY RUNTIME RESERVE	<p>NC/NO contacts 30 Vdc -1 A 125 Vac - 0,5 A (resistive load).</p> <p>Dry Contact</p> <p>When the function is activated, the contact switches from the normally closed (NC) terminal to the normally open (NO) terminal</p>
	CONFIG 1	NO-C-NO	<i>Functionality not available at this time</i>	
	OVL D	NO-C-NO	OVERLOAD	
	BYP STATUS	NO-C-NO	BYPASS STATUS	
	ALARM	NO-C-NO	ALARM	
	MAINS BAT	NO-C-NO	MAINS/BATTERY STATUS	
Analogic floating inputs	EXT TEMP	1-2	<i>Functionality not available at this time</i>	
Digital floating inputs	EXT IN BYP SW	1-2	EXTERNAL BYPASS SWITCH	
	MAINT BYP	1-2	EXTERNAL MAINTENANCE BYPASS SWITCH	<p>This contact enables the forced bypass mode.</p> <p>Note: The auxiliary contact cannot be used when the UPS is configured for single-phase input and 120° three-phase output.</p>
	EPO	1-2	Emergency Power Off (EPO) See par. 4.4.2	<p>Maximum input voltage: 5V 1 kΩ pull-up</p>
	EXT OUT SWITCH	1-2	EXTERNAL OUTPUT SWITCH	
	GENSET	1-2	GENSET This input allows the UPS to detect the presence of an external generator.	
	EXT BAT SWITCH	1-2	EXTERNAL BATTERY SWITCH	

4. Installation

4.4.4 Network Card (SNMP) Slot

At the rear of the UPS, there is a dedicated slot for installing an optional SNMP (Simple Network Management Protocol) card.

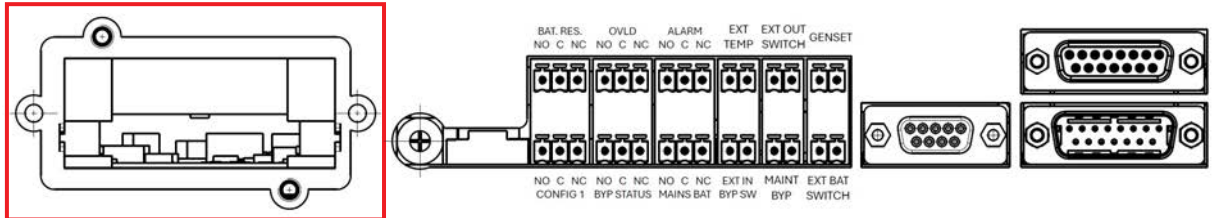

The total current drawn from the SNMP slot to power the network card must not exceed 700 mA.

5. Configuration and Start-up



All UPS installation operations must be carried out exclusively by a skilled technician (paragraph 2.1.1).

This chapter provides all necessary information for the correct configuration and initial startup of the UPS system.

The factory default configuration includes:

- Three-phase input
- 120° three-phase output

The UPS automatically detects:

- Input voltage
- Input frequency
- Number of phases

This automatic recognition occurs when the electrical connections on the terminal strip are modified accordingly.



Make sure the neutral wire is always connected.

The UPS does not automatically detect the electrical configuration on the output terminal strip. Therefore, it is mandatory to manually select the appropriate output voltage configuration from the control panel, based on the characteristics of the connected load.

For detailed guidance on selecting the correct output configuration, refer to paragraph 5.2.

5.1 Pre-Start-Up Checks

Before powering on the UPS system, perform the following checks to ensure safe and correct operation:

1. Ensure the mains input switch on the UPS is open (OFF position).
2. Ensure the bypass input switch on the UPS is open (OFF position).
3. If the UPS model includes them, verify that the battery fuse breakers are open (OFF position). If an external battery cabinet is present, ensure its fuse breakers are also open.
For TriMOD 30TT models with fuse breakers on the terminal strip, confirm that all battery drawers are not fully inserted, thereby interrupting the battery string.
4. Ensure the maintenance bypass switch and the output switch are both open (OFF position).
5. Confirm that all input and output wiring has been completed and that all connections are properly tightened.
6. Verify the correct phase sequence of the mains input and bypass line (if separate).
7. Ensure that the voltage and frequency of the input line are compatible with the values shown on the UPS rating plate.
8. Confirm that all power modules are properly inserted. Check that the fixing screws are present and fully tightened until they abut the slots. Use SHC M4x20 hex socket head screws.
9. Ensure that all battery drawers, if present, are properly inserted. Verify that all fixing screws are present and fully tightened.
For TriMOD 30TT, insert each battery drawer one at a time, push it fully in, and secure it with the appropriate screws.

5. Configuration and Start-up

5.2 Start-up Procedure

1. Insert the battery fuses into the appropriate fuse holders of the TriMOD UPS (if the model includes them) and into the external battery cabinets (if present).
2. Close the battery fuse breakers on both the UPS and the external battery cabinets (if present).



Before turning on the UPS, you must select the correct output configuration.

3. Press and hold the COLD START button for at least 5 seconds. The button is located at the upper left side of the UPS, accessible once the front door is opened. The display will turn on.
4. Tap the LOGIN icon. Enter the username and password found on the label near the product identification tag, then tap the *Login* button.

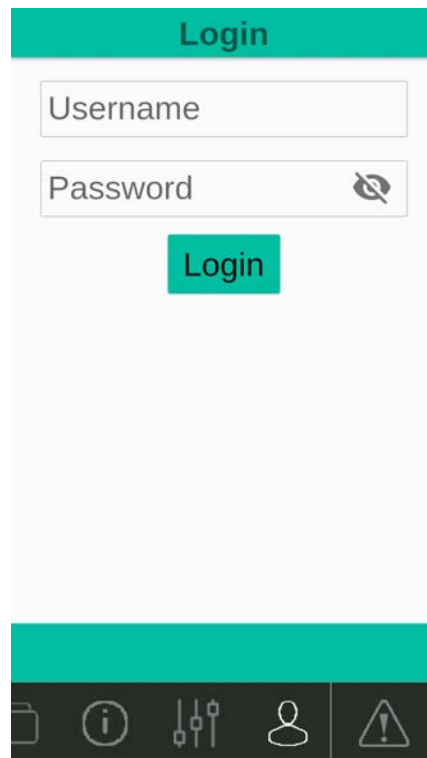

5. Tap the **SETTINGS** icon, then select the *Settings* button. In the *VRmsOut* menu, choose the desired output voltage. In the *InverterConfiguration* menu, select the appropriate inverter output configuration based on the type of load and the downstream distribution system.

 The inverter output configuration must match the wiring configuration set on the output terminal strip during installation. Incorrect connections or mismatched configurations may result in equipment damage or personal injury.

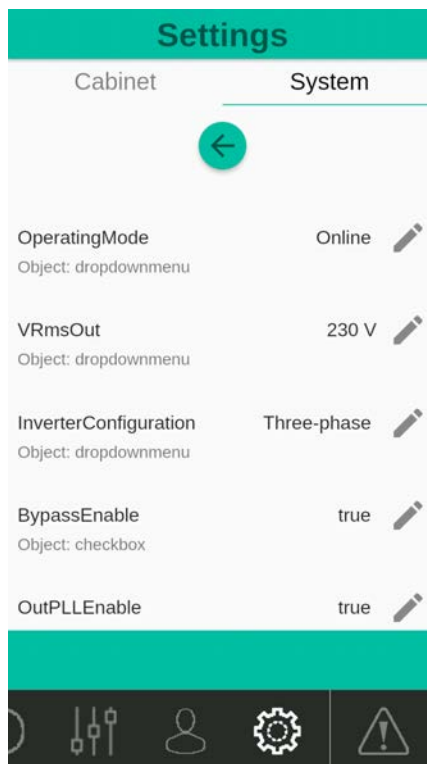

6. Tap the **BATTERY** icon, then select the *BD1* button under the Parameters menu.

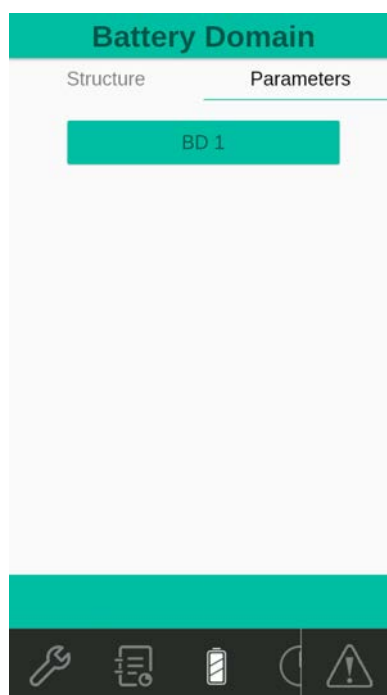

5. Configuration and Start-up

7. In the *TotalKB* field, enter the total number of Battery Kits (KB) installed. In the *CapacityKB* field, enter the battery capacity in ampere-hours (Ah) of a single KB. In the *BatteryNumInKB* field, enter the number of batteries contained in each battery kit (default value: 20).

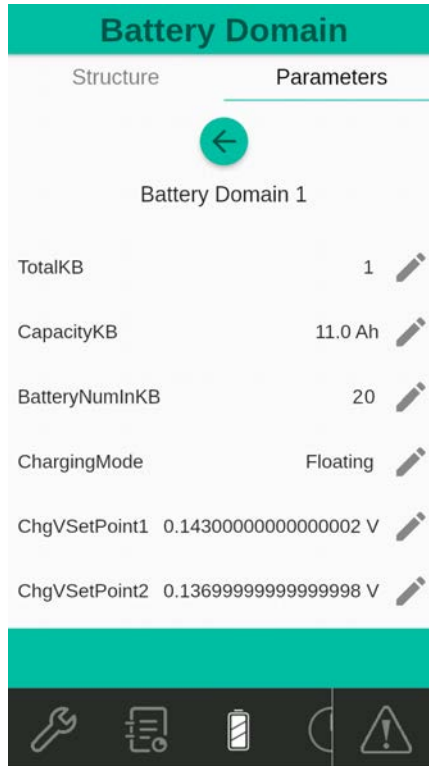

- One KB (Battery Kit) consists of a string of 20 batteries connected in series. For models equipped with internal battery drawers and external modular battery cabinets, one KB includes four battery drawers.

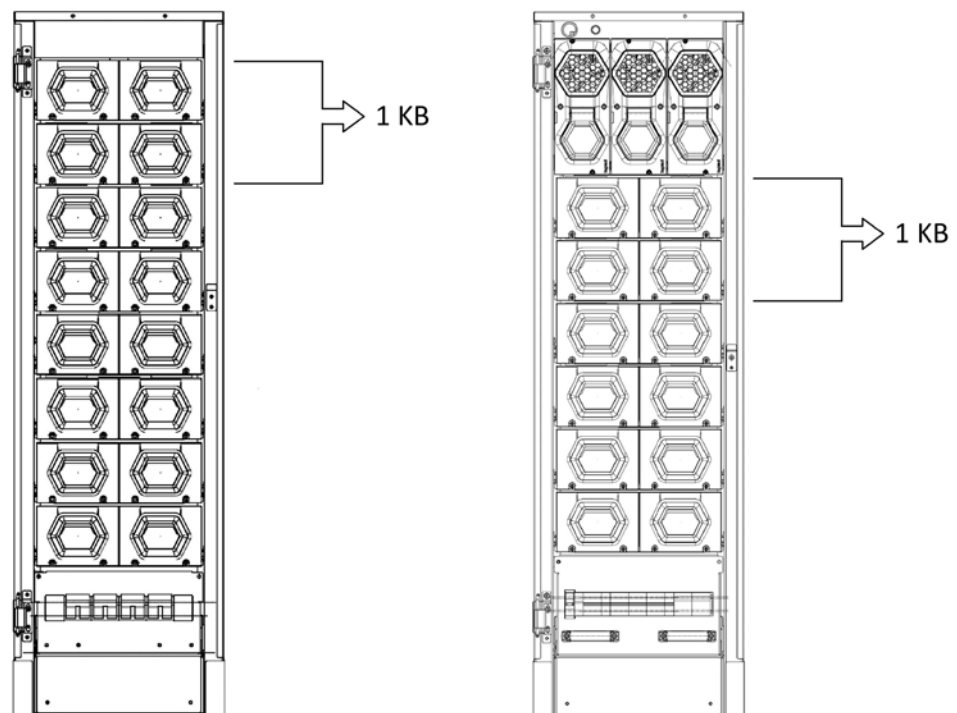

For modular battery cabinets with battery drawers, it is necessary to install one KB (Battery Kit) for every 10 kVA of the UPS's nominal power. For example, the TriMOD 40 TT requires at least one external modular battery cabinet containing 4 KB (equivalent to 16 battery drawers).

For external non-modular battery cabinets, each cabinet represents one KB, and a single KB is sufficient for all TriMOD models.

 The UPS calculates the total battery capacity by multiplying the number of installed Battery Kits (TotalKB) by the capacity of each kit (CapacityKB).

8. Tap the CLOCK icon, then select the *Set Time* button.

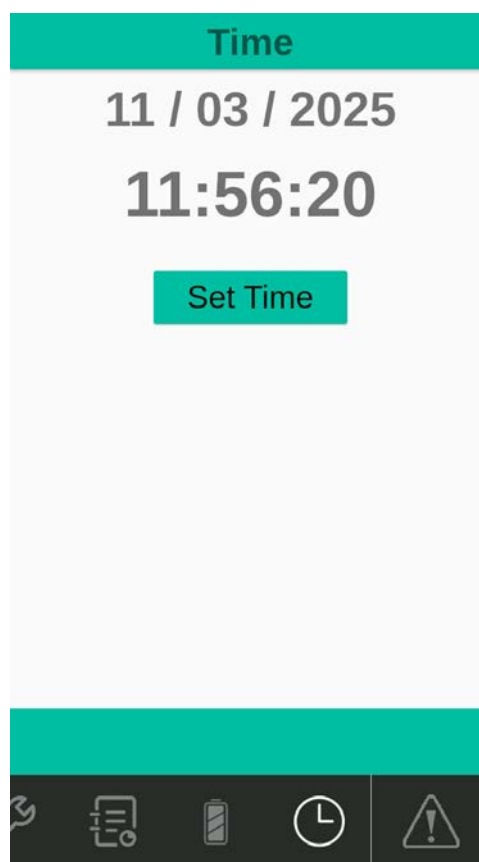

9. Set the correct date and time, then tap the *Confirm* button to save the changes.

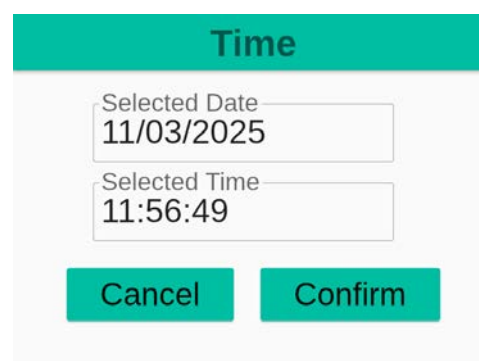

10. Supply power to the UPS by switching ON both the mains input switch and the bypass input switch.

5. Configuration and Start-up

11. Tap the GENERAL CONTROLS icon. To power on the UPS, tap the *Execute* button next to the *Power On* command.

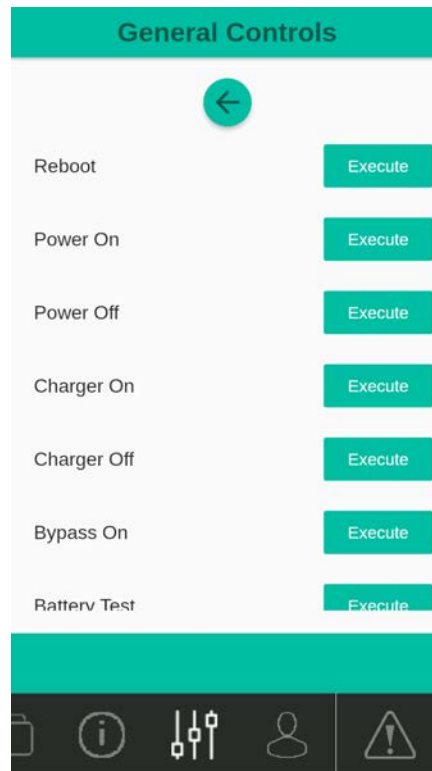

12. Tap *Yes* on the *Confirm* pop-up window to confirm the UPS power-on.

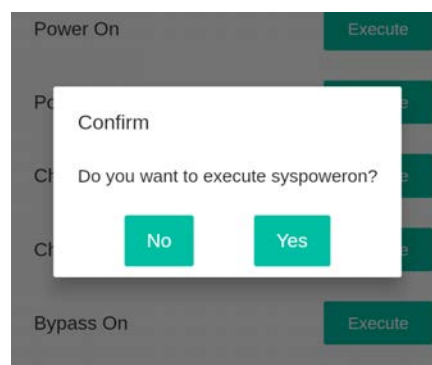



13. Once the UPS has completed its startup procedure, verify that the output voltage and frequency values match the requirements of the connected load.

14. Switch ON the UPS output breaker. At this point, the load will be powered by the UPS.

15. Close the UPS door and remove the key.

 If it is necessary to verify the proper operation of the UPS in battery mode during installation, disconnect the mains power using the circuit breaker located upstream of the UPS.

 The UPS is equipped with an auto-restart function. If mains power fails and the UPS reaches the end of its backup time, the load will automatically be powered again once mains power is restored—provided the auto-restart setting is enabled.

 The keys for opening the UPS door must not be left accessible to the operator. The installation manual must also be kept out of the operator's reach.

6. Maintenance



Ordinary maintenance operations must be performed only by skilled technicians (see paragraph 2.1.1). Extraordinary maintenance operations must be carried out exclusively by Legrand Technical Support Service.



Keep a register in which to enter the date, time, type and any other useful information about any routine and extraordinary maintenance operation.

6.1 Preventive Maintenance

The UPS does not contain any components that require preventive maintenance by the operator. However, the operator must periodically perform the following basic checks:

- General external cleaning of the UPS enclosure.
- Verification of the absence of alarms on the display.
- Check of fan operation on each power module to ensure proper cooling.

6.2 Periodical Checks

Regular maintenance inspections are essential to ensure the correct functioning and long-term reliability of the UPS.

During a preventive maintenance inspection, a qualified technician must perform the following checks:

- Absence of active alarms.
- Review of the event log.
- Proper operation of the static and maintenance bypass systems.
- Integrity of the electrical installation.
- Unobstructed airflow for cooling.
- Battery condition and performance.
- Characteristics of the connected load.
- Environmental conditions at the installation site.

If any issues are identified, contact Legrand Technical Support Service for assistance.

6.3 Extraordinary Maintenance

For any failures that require access to internal components of the UPS, contact Legrand Technical Support Service.

Only authorized personnel should perform internal servicing to ensure safety and maintain warranty coverage.



WARNING

Do not touch the backplane of the tunnel left uncovered for the removal of the power modules because there are dangerous live parts. On the cover of the power module there are two holes from which it is possible to see two leds that signal the presence of dangerous voltage on the rear connection. Before performing any operation on the power module, make sure that these leds are off. If they are on, wait for them to go off.

6. Maintenance

6.4 Maintenance procedure of the UPS in maintenance bypass mode

If the power module hot-swap replacement procedure is not applicable, it is possible to make the replacement with the UPS in maintenance bypass mode. This mode is also necessary to perform maintenance or replace parts such as command boards, backplanes, update the UPS firmware etc.



Direct activation of the bypass switch without performing the 'bypass maintenance procedure' may damage the UPS.



During forced and maintenance bypass operations, the load is not protected because it is supplied from the bypass input line.



The power modules may not be replaced without adhering scrupulously to the instructions below.

BYPASS MAINTENANCE PROCEDURE:

1. Enable the Bypass via the HMI menu (BYPASS ON → Execute)
2. Close the MAINTENANCE BYPASS switch
3. Open the OUTPUT switch
4. Switch off the UPS
5. Open the INPUT and BYPASS switch
6. Disconnect the BATTERIES

You can now work safely on the UPS.

PROCEDURE for restoring from MAINTENANCE BYPASS:

1. Reconnect the BATTERIES
2. Close the INPUT and BYPASS switch
3. Switch on the UPS
4. Close the OUTPUT switch
5. Open the MAINTENANCE BYPASS switch
6. Disable the Bypass via the HMI menu (BYPASS OFF → Execute)



In the case of models with internal batteries, some parts remain with dangerous voltage even after all the battery fuse breakers are opened. Remove at least one battery drawer for every shelf present in order to interrupt the battery string set.



Inside the upper section of the UPS, where the control boards and the contact interface board are located, hazardous voltage may be present due to the connection of the external backfeed control line. Pay close attention to the N7 connector on the contact interface board, to which the backfeed line is connected.

7. Warehousing



All storage operations must be carried out only by a skilled technician (paragraph 2.1.1)



A skilled technician must ensure there is no voltage present before disconnecting the cables. All battery breakers on the UPS and external battery cabinets must be open. The battery drawers of the TriMOD Modular Battery (if present) and the UPS (depending on the model) must be removed.

7.1 UPS

The UPS must be stored in an environment with a room temperature between -20°C (-4°F) and $+50^{\circ}\text{C}$ ($+122^{\circ}\text{F}$) and humidity less than 90% (non-condensing).

The package box must be elevated at least 200 mm off the ground and kept at least 500 mm away from walls, heat sources, cold sources, windows, or air inlets.

The storage area must be free from inflammable, explosive, or corrosive materials, as well as harmful gases. Additionally, the environment should be free from strong mechanical vibrations, impacts, or magnetic fields.

7.2 Batteries

Batteries can be stored without recharging under the following conditions:

- Up to 6 months if the temperature is between $+20^{\circ}\text{C}$ ($+68^{\circ}\text{F}$) and $+30^{\circ}\text{C}$ ($+86^{\circ}\text{F}$);
- Up to 3 months if the temperature is between $+30^{\circ}\text{C}$ ($+86^{\circ}\text{F}$) and $+40^{\circ}\text{C}$ ($+104^{\circ}\text{F}$);
- Up to 2 months if the temperature exceeds $+40^{\circ}\text{C}$ ($+104^{\circ}\text{F}$).



Batteries must never be stored if partially or fully discharged. LEGRAND is not liable for any damage or malfunction caused by improper storage of the batteries.

8. Dismantling and Disposal



Dismantling and disposal operations must be carried out only by a skilled technician (paragraph 2.1.1). The instructions in this chapter are to be considered indicative: in every country there are different regulations regarding the disposal of electronic or hazardous waste such as batteries. It is necessary to strictly adhere to the regulations in force in the country where the equipment is used. Do not throw any component of the equipment in the ordinary rubbish.

8.1 Battery Disposal

Batteries must be disposed of in a site intended for the recovery of toxic waste. Disposal in the traditional rubbish is not allowed. Apply to the competent agencies in your countries for the proper procedure.



Pb



Batteries may pose a risk of electric shock and high short-circuit current. When working on batteries, always follow the safety instructions provided in Chapter 2.

8.2 UPS Dismantling

The dismantling of the UPS must occur after the dismantling of the various parts it consists of. For the dismantling operations, it is necessary to wear the Personal Protective Equipment mentioned in paragraph 2.2. Sub-divide the components separating the metal from the plastic, from the copper and so on according to the type of selective waste disposal in the country where the equipment is dismantled. If the dismantled components must be stored before their disposal, be careful to keep them in a safe place protected from atmospheric agents to avoid soil and groundwater contamination.

8.3 Electronic Components Dismantling

For the disposal of electronic waste, it is necessary to refer to the relevant standards.



This symbol indicates that in order to prevent any negative effects on the environment and on people, this product should be disposed of separately from other household waste, by taking it to authorised collection centres, in accordance with the EU countries local waste disposal legislations. Disposing of the product without following local regulations may be punished by law. It is recommended to check that this equipment subject to WEEE legislations in the country where it is used.

9. Technical data

Main features

	3 112 75 3 112 76 3 112 77 3 112 78 3 112 89 3 112 90 3 112 97 3 112 98	3 112 79 3 112 80 3 112 81 3 112 91 3 112 92 3 112 99 3 113 01	3 112 82 3 112 83 3 112 84 3 112 93 3 112 94 3 112 99 3 113 00 3 113 01 3 113 08*	3 113 03 3 113 08*	3 113 08*	3 112 85 3 112 95 3 112 96 3 113 02 3 113 04 3 113 09*	3 112 86 3 113 05 3 113 10*	3 112 87 3 113 06 3 113 11*	3 112 88 3 113 07 3 113 12*
	10 kVA	15 kVA	20 kVA	30 kVA TM	40 kVA TM	30 kVA TT	40 kVA TT	60 kVA	80 kVA
Nominal power (kVA)	10	15	20	30	40	30	40	60	80
Active Power (kW)	10	15	20	30	40	30	40	60	80
Technology	online, double conversion VFI-SS-11 (EN IEC 62040-3)								
Multiple normal mode	VFI, VFD, VI								
IN/OUT Configuration	3P / 3P (default) 1P / 1P 1P / 3P 3P / 1P					3P / 3P			
AC power distribution system compatibility	TT, TN-C, TN-S, IT								
Command boards	1				1 (2 for the MULTI CTRL 3 113 08-09-10)			1 (3 for the MULTI CTRL 3 113 11)	1 (4 for the MULTI CTRL 3 113 12)
Neutral system	Neutral passing straight from input to output (not isolated)								
Bypass	Automatic (static and electromechanical) Manual (for maintenance)								
Protection class	I								
Overvoltage category	OVC II								

9. Technical data

Input electrical characteristics

	3 112 75 3 112 76 3 112 77 3 112 78 3 112 89 3 112 90 3 112 97 3 112 98	3 112 79 3 112 80 3 112 81 3 112 91 3 112 92 3 112 99 3 113 01	3 112 82 3 112 83 3 112 84 3 112 93 3 112 94 3 112 99 3 113 00 3 113 01 3 113 08*	3 113 03 3 113 08*	3 113 08*	3 112 85 3 112 95 3 112 96 3 113 02 3 113 04 3 113 09*	3 112 86 3 113 05 3 113 10*	3 112 87 3 113 06 3 113 11*	3 112 88 3 113 07 3 113 12*
	10 kVA	15 kVA	20 kVA	30 kVA TM	40 kVA TM	30 kVA TT	40 kVA TT	60 kVA	80 kVA
Maximum 3P/3P input current (A)	19.2	28.8	38.4	57.6	76.8	57.6	76.8	115.2	153.6
Maximum 3P/1P input current (A)	19.2	28.8	38.4	57.6	76.8	-	-	-	-
Maximum 1P/3P input current (A)	57.6	86.4	115.2	172.8	230	-	-	-	-
Maximum 1P/1P input current (A)	57.6	86.4	115.2	172.8	230	-	-	-	-
Nominal input voltage (V)	230 + 15% - 20% (1P) 400 + 15% - 20% (3P)					400 + 15% - 20%			
Power factor on input	> 0.99								
Total harmonic distortion of the input current	THDi < 3.5% (full load)								

Bypass electrical characteristics

	3 112 75 3 112 76 3 112 77 3 112 78 3 112 89 3 112 90 3 112 97 3 112 98	3 112 79 3 112 80 3 112 81 3 112 91 3 112 92 3 112 99 3 113 01	3 112 82 3 112 83 3 112 84 3 112 93 3 112 94 3 112 99 3 113 00 3 113 01 3 113 08*	3 113 03 3 113 08*	3 113 08*	3 112 85 3 112 95 3 112 96 3 113 02 3 113 04 3 113 09*	3 112 86 3 113 05 3 113 10*	3 112 87 3 113 06 3 113 11*	3 112 88 3 113 07 3 113 12*
	10 kVA	15 kVA	20 kVA	30 kVA TM	40 kVA TM	30 kVA TT	40 kVA TT	60 kVA	80 kVA
Bypass rated voltage (V)	230 + 15% - 20% (1P) 400 + 15% - 20% (3P)								
Bypass rated frequency (Hz)	50 / 60 ± 14%								
Icc max (kA)	10								
Maximum I ² t (A ² s) (10 ms)	10,15,20 kVA: 4000 30,40 kVA: 16000 60 kVA: 36000 80 kVA: 64000								

Output electrical characteristics

	3 112 75 3 112 76 3 112 77 3 112 78 3 112 89 3 112 90 3 112 97 3 112 98	3 112 79 3 112 80 3 112 81 3 112 91 3 112 92 3 112 99 3 113 01	3 112 82 3 112 83 3 112 84 3 112 93 3 112 94 3 112 99 3 113 00 3 113 01 3 113 08*	3 113 03 3 113 08*	3 113 08*	3 112 85 3 112 95 3 112 96 3 113 02 3 113 04 3 113 09*	3 112 86 3 113 05 3 113 10*	3 112 87 3 113 06 3 113 11*	3 112 88 3 113 07 3 113 12*
	10 kVA	15 kVA	20 kVA	30 kVA TM	40 kVA TM	30 kVA TT	40 kVA TT	60 kVA	80 kVA
Maximum 3P/3P output current (A)	14.5	21.7	29	43.5	58	43.5	58	87	116
Maximum 3P/1P output current (A)	43.5	65.2	87	130.5	174	-	-	-	-
Maximum 1P/3P output current (A)	14.5	21.7	29	43.5	58	-	-	-	-
Maximum 1P/1P output current (A)	43.5	65.2	87	130.5	174	-	-	-	-
Nominal output voltage (V)	230 ± 1% (1P) 400 ± 1% (3P)					400 ± 1%			
Nominal output frequency (Hz)	50 / 60								
Tolerance on the output frequency	If synchronized with the input frequency: ± 0.5 to 7.0 If not synchronized: ± 0.05								
Crest factor admitted on the output current	3:1								
Efficiency (AC/AC on-line)	up to 96.5%								
Efficiency ECO mode	up to 99.2%								
Total harmonic distortion of output voltage at rated power	THDv < 1% (linear load)								
Overload	115% for 10 minutes without automatic bypass intervention 135% for 1 minute without automatic bypass intervention								
Minimum inverter current limit (n x In, x ms)	ik1, ik2: 2 x In								

9. Technical data

Electrical output characteristics (battery operation)

	10 kVA	15 kVA	20 kVA	30 kVA TM	40 kVA TM	30 kVA TT	40 kVA TT	60 kVA	80 kVA
Nominal output voltage	230 V ± 1% (Single-phase) 400 V ± 1% (Three-phase)					400 V ± 1% (Three-phase)			
Output frequency	50 / 60 Hz ± 1%								
Total harmonic distortion of output voltage on nominal non-linear load	< 1%								
Overload capacity	115% for 2 minutes 120% for 1 minute 20 seconds								
Shortcircuit	I _{cc} = 2.4 I _n for 50 ms I _{cc} = 1.65 I _n for 1 sec								

Batteries and Battery Charger Characteristics

Battery type	Lead-acid sealed without maintenance (VRLA)
Rated battery voltage	240 Vdc (20 x 12 Vdc batteries in series)
Type of battery charger	High performance PWM, one for each power module
Nominal recharge current battery charger	2.5 A max for every power module installed

Features

Display	5" colour touchscreen
Communications ports	1xRS232, 1xslot SNMP, 1xUSB (service), 1xUSB host port
Auxiliary Signal	6 output floating contacts, 5 input floating contacts (including EPO), external temperature sensor, external bypass
Protections	Backfeed protection (NC/NO auxiliary contact) Emergency Power Off (EPO) Electronic against overloads, short-circuit and excessive battery discharge Block of functions due to end of autonomy In-rush limiter on start-up Internal battery circuit fuses (for internal battery drawers)

Mechanical characteristics

Power module net weight (kg)	7.94
9Ah Battery drawer net weight (kg)	13.94

	Empty power cabinets							
	3 112 97	3 112 99	3 112 99 3 113 08*	3 113 03 3 113 08*	3 113 08*	3 113 02	3 113 05 3 113 10*	3 113 06 3 113 11*
	10 kVA	15 kVA	20 kVA	30 kVA TM	40 kVA TM	30 kVA TT	40 kVA TT	60 kVA
Net weight (kg)	74	79	79	78 79*	79	73	73 74	77 79*
Dimensions W x H x D (mm)	414 x 1370 x 628							
Number of installable 3400 VA power modules	3	-	6*	-	-	-	-	-
Number of installable 5000 VA power modules	-	3	-	6	-	6	-	-
Number of installable 6700 VA power modules	-	-	3 (3 112 99)	-	6	-	6	9
Number of installable battery drawers	12	12	12 (3 112 99) 0*	-	-	-	-	-

	Empty power cabinets				
	3 112 98	3 113 01	3 113 00 3 113 01	3 113 04 3 113 09*	3 113 07 3 113 12*
	10 kVA	15 kVA	20 kVA	30 kVA TT	80 kVA
Net weight (kg)	86	91	91	91 92*	95 97*
Dimensions W x H x D (mm)	414 x 1650 x 628				
Number of installable 3400 VA power modules	3	-	6 (3 113 00)	-	-
Number of installable 5000 VA power modules	-	3	-	6	-
Number of installable 6700 VA power modules	-	-	3 (3 113 01)	-	12
Number of installable battery drawers	16	16	12 (3 113 00) 16 (3 113 01)	12	-

9. Technical data

Mechanical characteristics

	Power cabinets with PM					
	3 112 89 10 kVA	3 112 91 15 kVA	3 112 93 20 kVA	3 112 95 30 kVA TT	3 112 86 40 kVA TT	3 112 87 60 kVA
Net weight (kg)	100	105	105	124	124	154
Dimensions W x H x D (mm)	414 x 1370 x 628					
Number of installable 3400 VA power modules	3	-	-	-	-	-
Number of installable 5000 VA power modules	-	3	-	6	-	-
Number of installable 6700 VA power modules	-	-	3	-	6	9
Number of installable battery drawers	12	12	12	-	-	-

	Power cabinets with PM				
	3 112 90 10 kVA	3 112 92 15 kVA	3 112 94 20 kVA	3 112 96 30 kVA TT	3 112 88 80 kVA
Net weight (kg)	112	117	117	142	197
Dimensions W x H x D (mm)	414 x 1650 x 628				
Number of installable 3400 VA power modules	3	-	-	-	-
Number of installable 5000 VA power modules	-	3	-	6	-
Number of installable 6700 VA power modules	-	-	3	-	12
Number of installable battery drawers	16	16	16	12	-

Mechanical characteristics

	UPS (PM + battery drawers)						
	3 112 75	3 112 76	3 112 77	3 112 79	3 112 80	3 112 82	3 112 83
	10 kVA	10 kVA	10 kVA	15 kVA	15 kVA	20 kVA	20 kVA
Net weight (kg)	167	223	279	220	279	220	279
Dimensions W x H x D (mm)	414 x 1370 x 628						
Power modules (PM4) 3400VA installed	3	3	3	-	-	-	-
Power modules (PM6) 5000VA installed	-	-	-	3	3	-	-
Power modules (PM7) 6700VA installed	-	-	-	-	-	3	3
Number of battery drawers installed (9Ah)	4	8	12	8	12	8	12

	UPS (PM + battery drawers)			
	3 112 78	3 112 81	3 112 84	3 112 85
	10 kVA	15 kVA	20 kVA	30 kVA
Net weight (kg)	350	350	350	325
Dimensions W x H x D (mm)	414 x 1650 x 628			
Power modules (PM4) 3400VA installed	3	-	-	-
Power modules (PM6) 5000VA installed	-	3	-	6
Power modules (PM7) 6700VA installed	-	-	3	-
Number of battery drawers installed (9Ah)	4	16	16	12

9. Technical data

Environmental conditions

Operating temperature (°C)	0 to 40
Relative humidity during operation	10% to 75% (non-condensing)
Storage temperature (°C)	-25 to +55 (excluding batteries)
Noise level at 1 metre (dBA)	58 to 62
Pollution degree	PD2
Climatic class (EN IEC 60721-3-3)	3K22
Special climatic class (EN IEC 60721-3-3)	3Z2
Biological class (EN IEC 60721-3-3)	3B2
Mechanical class (EN IEC 60721-3-3)	3M11
Mechanically active substances class (EN IEC 60721-3-3)	3S5
Ingress Protection Marking	IP 20
Maximum Altitude without derating	1000 metres above sea level
Heat dissipation (BTU/h)	80 kVA: 3,68 kW @100% load 40 kVA: 1,84 kW @100% load 20 kVA: 0,92 kW @100%load 10 kVA: 0,46 kW @100% load

Reference directive and standards

Marks	CE, UKCA, CMIM
Safety	2014/35/EU Directive EN IEC 62040-1
EMC	2014/30/EU Directive EN IEC 62040-2
Performance and test requirements	EN IEC 62040-3

10. Tables



 The selection of power cable type and cross-section must be based on voltage, rated current, and operating temperature, as well as compliance with local and national wiring standards and regulations. LEGRAND is not responsible for the correct sizing of cables, as this depends on the specific requirements of each electrical installation. The following tables provide guidance on recommended wire cross-sections for unipolar cables installed in PVC conduits and in air.

TABLE 1
Recommended Minimum Wire Cross-Sections

POWER	INPUT PHASES	OUTPUT PHASES	INPUT CABLE	BYPASS CABLE (in case of separate bypass line)	OUTPUT CABLE
10 kVA	3	3	5 x 4 mm ²	5 x 4 mm ²	5 x 4 mm ²
	1	1	3 x 10 mm ²	3 x 10 mm ²	3 x 10 mm ²
	1	3	3 x 10 mm ²	3 x 10 mm ²	5 x 4 mm ²
	3	1	5 x 10 mm ²	5 x 10 mm ²	3 x 10 mm ²
15/20 kVA	3	3	5 x 10 mm ²	5 x 10 mm ²	5 x 10 mm ²
	1	1	3 x 25 mm ²	3 x 25 mm ²	3 x 25 mm ²
	1	3	3 x 25 mm ²	3 x 25 mm ²	5 x 10 mm ²
	3	1	5 x 25 mm ²	5 x 25 mm ²	3 x 25 mm ²
30 kVA TM	3	3	5 x 16 mm ²	5 x 16 mm ²	5 x 16 mm ²
	1	1	3 x 50 mm ²	3 x 50 mm ²	3 x 50 mm ²
	1	3	3 x 50 mm ²	3 x 50 mm ²	5 x 16 mm ²
	3	1	5 x 50 mm ²	5 x 50 mm ²	3 x 50 mm ²
30 kVA TT	3	3	5 x 16 mm ²	5 x 16 mm ²	5 x 16 mm ²
40 kVA TM	3	3	5 x 25 mm ²	5 x 25 mm ²	5 x 25 mm ²
	1	1	3 x 70 mm ²	3 x 70 mm ²	3 x 70 mm ²
	1	3	3 x 70 mm ²	3 x 70 mm ²	5 x 25 mm ²
	3	1	5 x 70 mm ²	5 x 70 mm ²	3 x 70 mm ²
40 kVA TT	3	3	5 x 25 mm ²	5 x 25 mm ²	5 x 25 mm ²
60 kVA	3	3	5 x 35 mm ²	5 x 35 mm ²	5 x 35 mm ²
80 kVA	3	3	5 x 50 mm ²	5 x 50 mm ²	5 x 50 mm ²

 The maximum cable cross section that can be installed in the terminals is 70 mm² for all the models. The terminals are suitable for connection of both copper and aluminum conductors.

10. Tables

TABLE 2

Recommended Automatic Circuit Breakers for Mains Input and Bypass Line

POWER	INPUT PHASES	OUTPUT PHASES	AUTOMATIC CIRCUIT BREAKER RECOMMENDED
10 kVA	3	3	C curve 20A (3P+N)
	3	1	C curve 63A (3P+N)
	1	1-3	C curve 63A (1P+N)
15kVA	3	3	C curve 32A (3P+N)
	3	1	C curve 100A (3P+N)
	1	1-3	C curve 100A (1P+N)
20 kVA	3	3	C curve 40A (3P+N)
	3	1	C curve 100A (3P+N)
	1	1-3	C curve 100A (1P+N)
30 kVA TM	3	3	C curve 63A (3P+N)
	3	1	C curve 160A (3P+N)
	1	1-3	C curve 160A (1P+N)
30 kVA TT	3	3	C curve 63A (3P+N)
40 kVA TM	3	3	C curve 80A (3P+N)
	3	1	C curve 200A (3P+N)
	1	1-3	C curve 200A (1P+N)
40 kVA TT	3	3	C curve 80A (3P+N)
60 kVA	3	3	C curve 100A (3P+N)
80 kVA	3	3	C curve 150A (3P+N)

TABLE 3

Recommended Residual Current Circuit Breakers for Mains Input and Bypass Line

POWER	RESIDUAL CURRENT BREAKER RESIDUAL CURRENT ($I_{\Delta n}$)
10 kVA	≥ 300 mA B type
15 kVA	
20 kVA	
30 kVA TT/TM	
40 kVA TT/TM	
60 kVA	
80 kVA	

TABLE 4
Maximum Battery Current at Full Load and Recommended Fuse Ratings for External Battery Cabinets

POWER MODULE (kVA)	MAXIMUM BATTERY CURRENT PER MODULE (A)	NUMBER OF MODULES	1 Battery Cabinet		2 Battery Cabinets	
			MAXIMUM BATTERY CURRENT (A)	RECOMMENDED FUSE RATING (A)	MAXIMUM BATTERY CURRENT (A)	RECOMMENDED FUSE RATING (A)
6.7	35	3	100	125	55	63
		6	202	250	111.1	125
		9	304	400	167.2	200
		12	405	450	222.8	250
5	26	3	76	80	41.8	50
		6	152	160	83.6	100
3	18	3	50	63	27.5	35
		6	103	125	56.7	63

POWER MODULE (kVA)	MAXIMUM BATTERY CURRENT PER MODULE (A)	NUMBER OF MODULES	3 Battery Cabinets		4 Battery Cabinets	
			MAXIMUM BATTERY CURRENT (A)	RECOMMENDED FUSE RATING (A)	MAXIMUM BATTERY CURRENT (A)	RECOMMENDED FUSE RATING (A)
6.7	35	3	36.7	50	27.5	35
		6	74.1	80	55.6	63
		9	111.5	125	83.6	100
		12	148.5	160	111.4	125
5	26	3	27.9	35	20.9	35
		6	55.7	63	41.8	50
3	18	3	18.3	20	13.8	15
		6	37.8	50	28.3	35

Use only DC ultra rapid fuses type aR or gR with Icc ≥ 10 kA.

Fuse Calculation formula:

$$\text{Single battery cabinet: } I_f(A) \geq \frac{I_{\max} * N. PM}{N. Fuse/pole}$$

$$\text{Multiple battery cabinets: } I_f(A) \geq \frac{1.1 * I_{\max} * N. PM}{N. Cab * N. Fuse/pole}$$

If = current size of the fuse (per pole for each battery cabinet)

I_{max} = Maximum battery current of each PM (35A for the 6,7kVA, 26A for the 5kVA, 18A for the 3kVA)

N. PM = Number of PM

N. cab = Number of battery cabinets installed

N. Fuse/pole = Number of fuses in parallel per battery pole



The table refers to 1 fuse per battery pole. It is also allowed to use a maximum of 2 fuses in parallel per pole (dividing by 2 the current rating compared to the current rating of a single fuse per pole).



The minimum wire cross-section required for connecting the UPS to external battery cabinets depends on the number of battery cabinets installed. Always consider the maximum current based on the specific installation type.

TABLE 5

Maximum current absorbed by batteries at 100% load and minimum recommended cable cross-sections for connecting the UPS to external battery cabinets

POWER	MAXIMUM BATTERY CURRENT	MINIMUM RECOMMENDED CABLE CROSS-SECTION
10 kVA	50 A	1 x 10 mm ² for each pole
15 kVA	76 A	1 x 16 mm ² for each pole
20 kVA	100 A	1 x 25 mm ² for each pole
30 kVA TT/TM	152 A	2 x 25 mm ² for each pole
40 kVA TT/TM	202 A	2 x 35 mm ² for each pole
60 kVA	304 A	2 x 50 mm ² for each pole
80 kVA	405 A	2 x 70 mm ² for each pole

11. Dimensional Drawings

11.1 Cabinet with h = 1650 mm

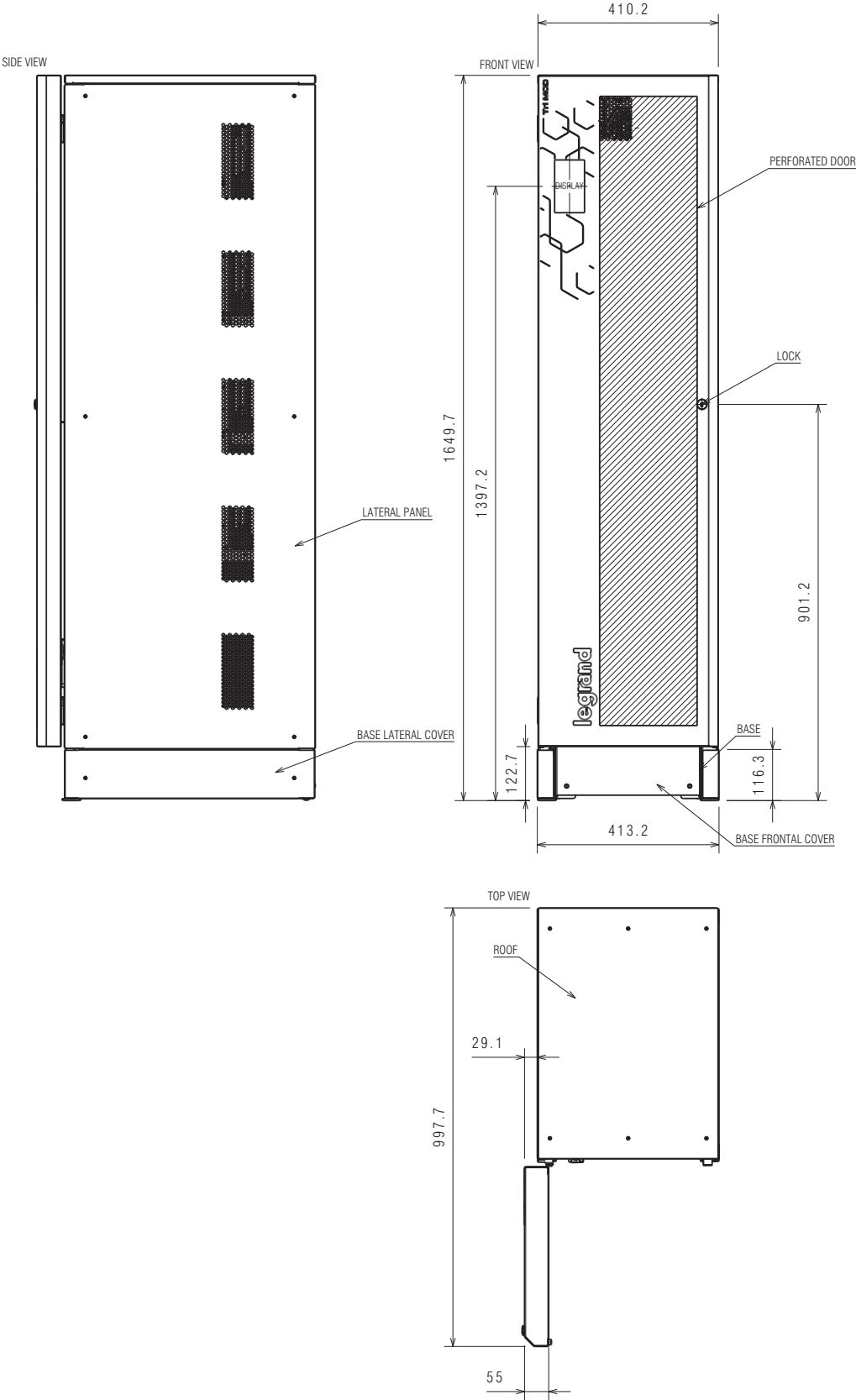

11. Dimensional Drawings

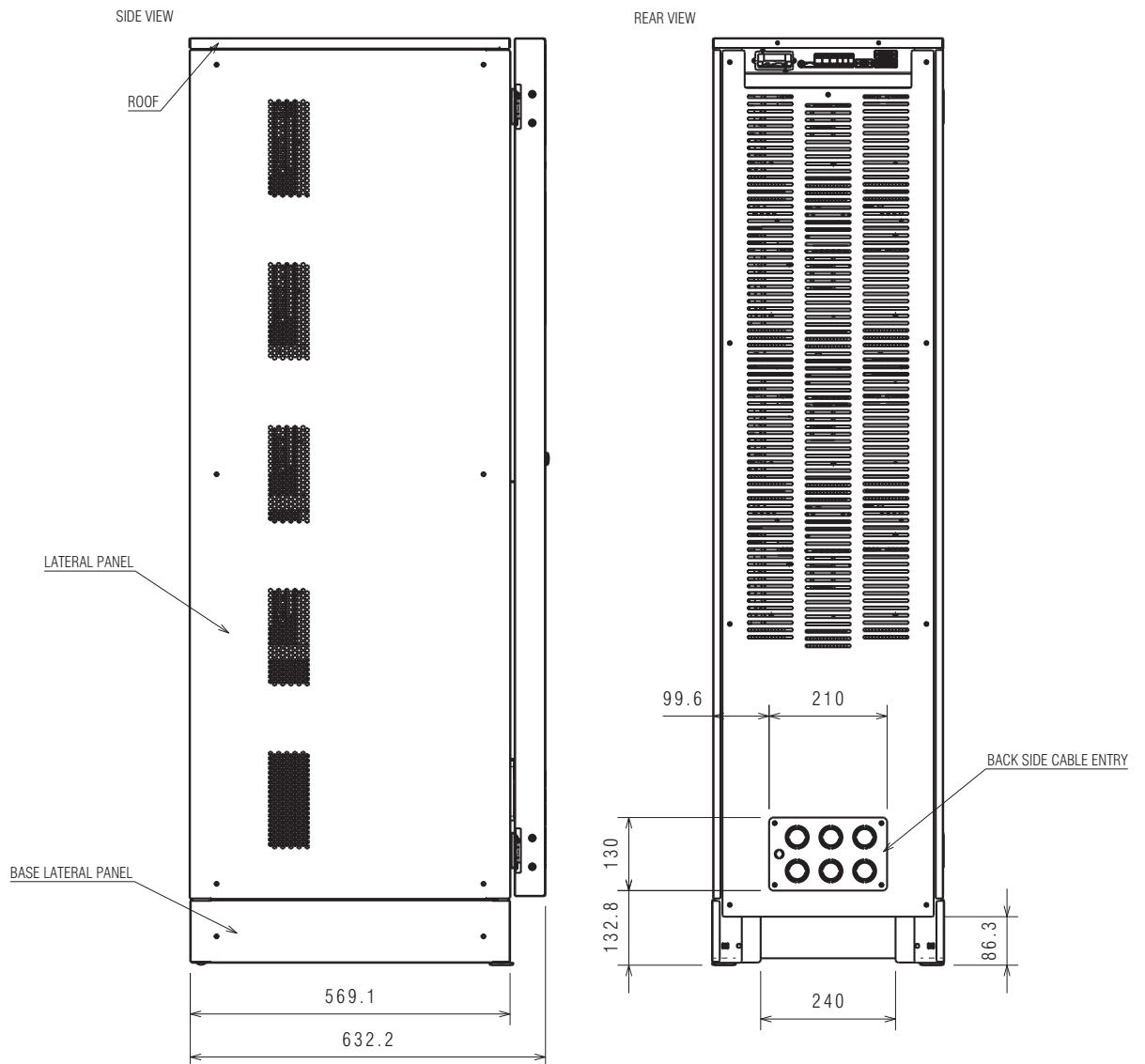

11.2 Cabinet with h = 1370 mm

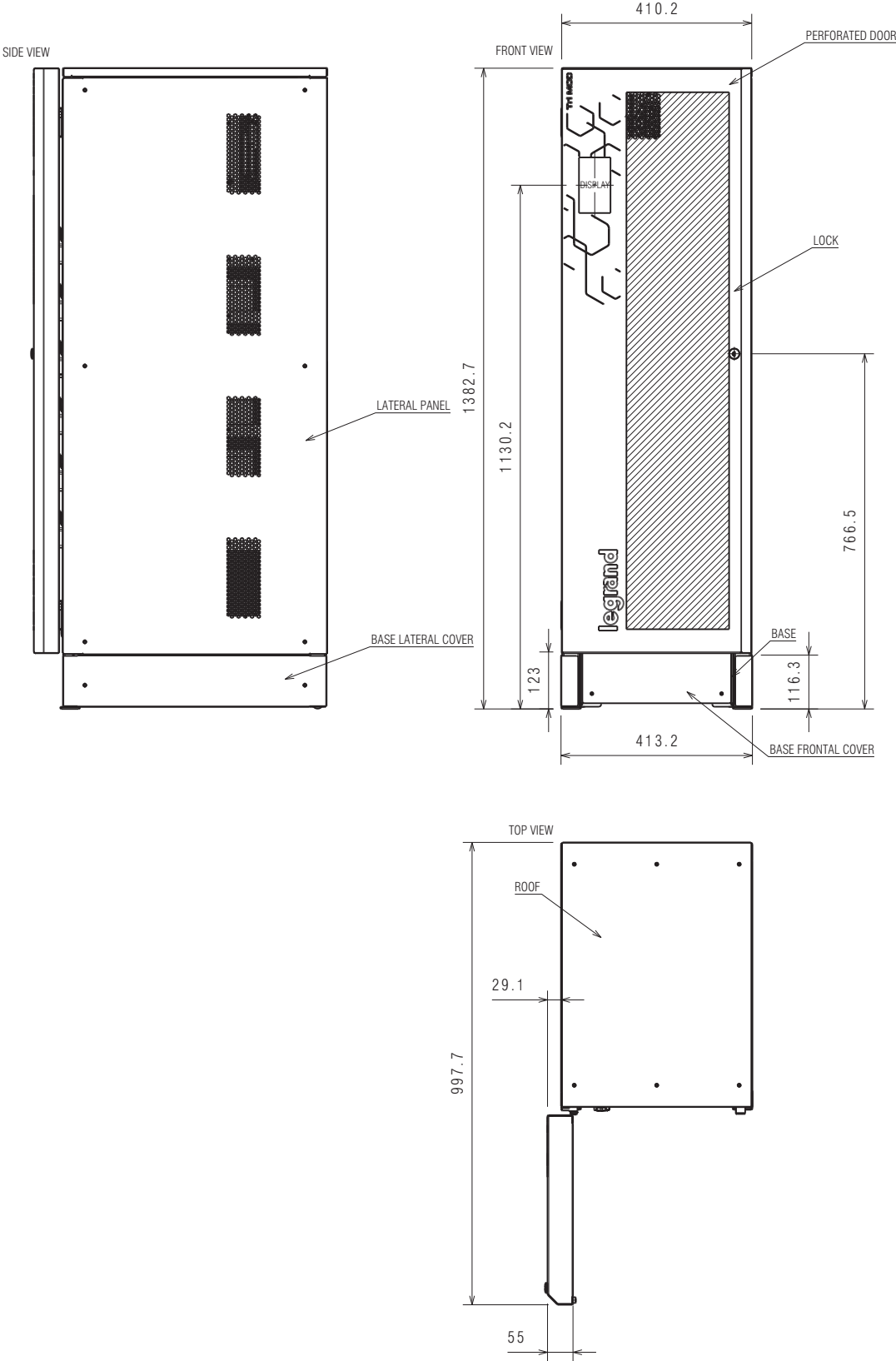

11. Dimensional Drawings

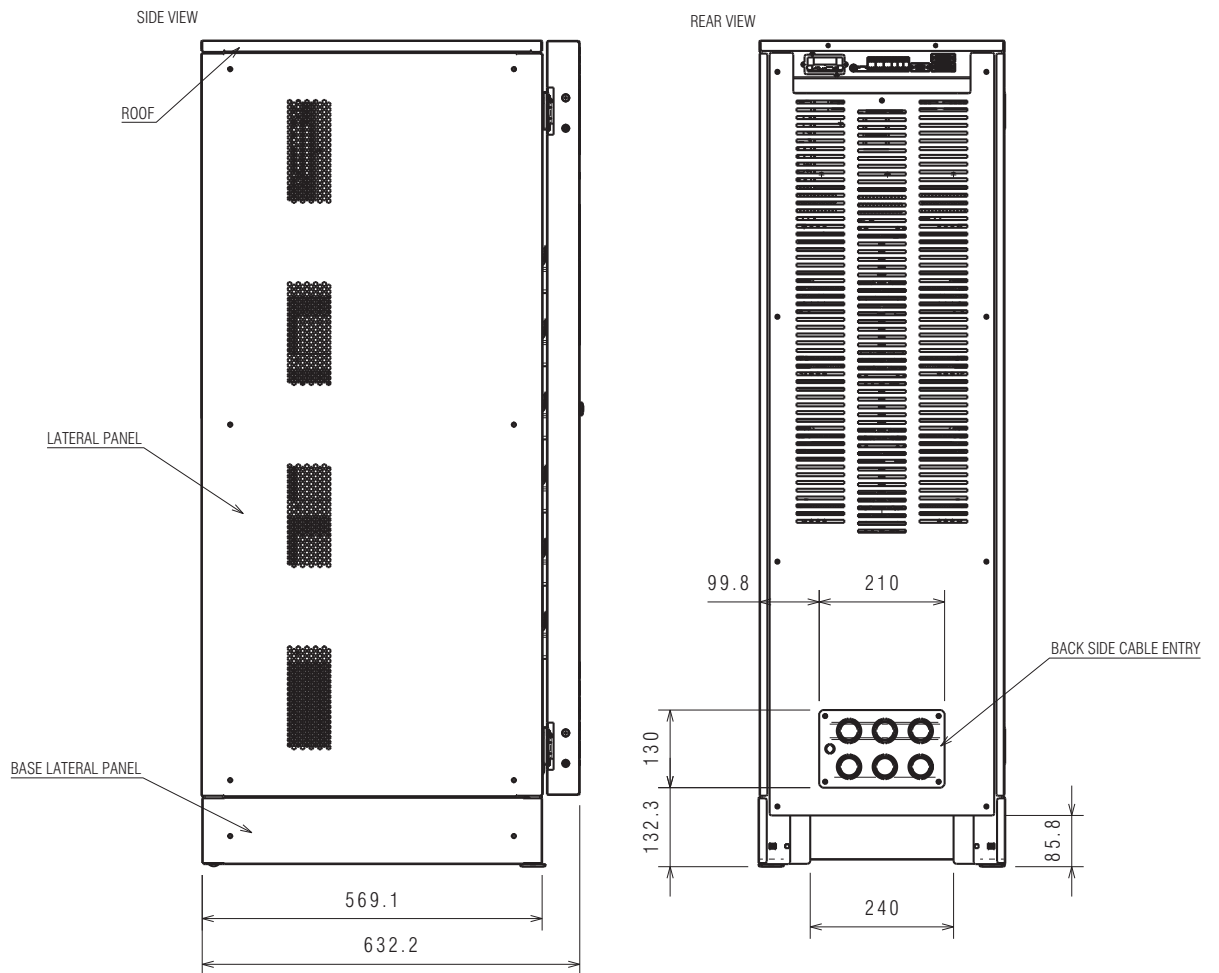

12. Battery Regulation

	311275 311324	311276 311279 311282 311325	311277 311280 311283 311285 311326	311278 311281 311284 311327	311328
Nominal Voltage (V)	240 V				
Rated Capacity (Ah)	8.4	16.8	25.2	33.6	42
Capacity Fade (%)	-30% to -20%				
Power (KW)	4	8	12	16	20
Power Fade (%)	-30% to -20%				
Internal Resistance (mΩ)	38	19	12.7	9.5	7.6
Resistance increase (%)	+50%				
Round Trip Efficiency	N.A				
Efficiency fade	N.A				
Expected Lifetime (Years)	5				

Compliance Note:

The values provided above are for reference to estimate the performance and durability parameters of a battery pack with a total rated capacity >2kWh.

Actual values may vary based on practical applications, maintenance and environmental conditions.





LEGRAND
Pro and Consumer Service
BP 30076 - 87002
LIMOGES CEDEX FRANCE
www.legrand.com

┌ Installer stamp ─┐

└ ─┐